



# Newsletter

In this Newsletter:

- 1 | Message from the Director  
PRODUCT FOCUS:  
PLX20 Beams
- 2 | CASE STUDY:  
Freedom Building, Rotorua  
FAQ Video Series
- 3 | BEHIND OUR BRAND:  
New Opti Machne  
Welcome Lyla McLean  
Meet the Team Video

## WELCOME TO OUR MARCH 2021 ISSUE



Dear Customers

We are looking forward to 2021, we can see it as being a great year for the company and a great year for construction all over New Zealand. We are committed to supply lines and are currently putting in our own sawmill to ensure our supply is not hindered. This year we have just installed a new optimizer which has tripled our production capacity. A new Finger-Jointer will be installed at the end of March and new kilns in May and June. These new developments will help improve supply to our customers and to the New Zealand building industry. My personal goal for this year is to be a better communicator. In these difficult and uncertain times, I think communication is key, especially with our customers, suppliers, and staff.

I think we all need to be inspired by the way New Zealand is responding to the COVID 19 pandemic. We've got a government which is doing a great job here and overall I think the country is in a good space. There are lots of opportunities in the construction market that we need to take advantage of and build on for the future.

Thats all from me, remember to keep safe, keep well and keep supporting those near you.

Regards

John Woodman

Managing Director

## PRODUCT FOCUS: NEW PLX20 Beams

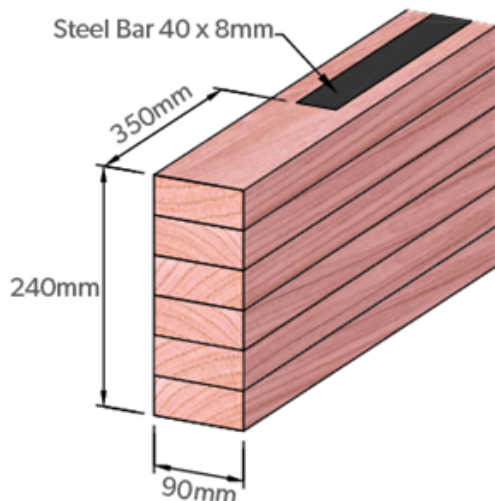

The Prolam PLX20 is an innovative Structural laminated beam becoming the ideal choice for Garage Door lintels being the highest strength beam in the Prolam Range. Manufactured using Pine radiata with steel inserted into top and bottom laminates to increase strength to increase spanning Capabilities.

It is the responsibility of the designer to establish hold down fixing's accordance with NZS3604:2012 or an alternative fixing solution.

### Key Features and Benefits

- Light weight
- Labour Savings – quicker to install
- Span further with smaller member
- Competitively priced
- Easy to Specify using Prolam Specifier [specifier.prolamnz.com](http://specifier.prolamnz.com)

Product Details

Code: PLX20-250100

Sizes: 240x90x5.4

Treatment: H1.2

Grade: Non-Visual

Applications: Lintels and Rafters

For further information and technical support, please contact our team on 03 526 7436 or [info@prowoodnz.com](mailto:info@prowoodnz.com)

# CASE STUDY: Freedom Building, Rotorua

Prolam approached Darryl from DCA Architects after spotting this awesome project on ArchiPro.

## What can you tell us about this project?

*"As the name suggests, it was formerly the retail and warehouse outlet for Freedom Furniture and Paint warehouse. TPB Properties Ltd purchased the building and developed it into A grade offices for a consulting firm and a law firm. While some structural upgrades were required the brief was to leave the existing structure of the building in place. The building is located with sightlines to the Prince's Gate timber archway leading to the Government Gardens. We decided to use a timber lattice on the exterior to partially disguise the masonry walls, while making reference to the timber lattice on the Prince's Gate. The use of timber is also in line with the local councils Wood First policy."*



## Why did you specify Prolam products in this project?

*"We were familiar with the Prolam range of products having used them on previous projects. The ease of choosing and specifying timber sizes and treatment levels is easy. The contractors never seem to have any supply chain delays getting product into site."*

## What Prolam products were specified?

*"PLP 100 H3.2 vertical posts and PLP 150 x 50 H3.2 horizontal lathes."*

## How are the Prolam products been used in this project?

*"The vertical posts and the horizontal lattice have been applied as a non structural external wall façade treatment. They were chosen for their stability to not twist or warp in the weather."*



## FAQ VIDEO SERIES

Did you know our technical team have been hard at work last year turning our FAQs into videos? Click [HERE](#) to check them out on our YouTube channel.



**What Voids My Warranty**



**Why No PL17?**



**LVL15 over against other LV...**

Is your question not answered?

Let us know if there is anything you would like help with by emailing [info@prowoodnz.com](mailto:info@prowoodnz.com).

## BEHIND OUR BRAND: New Opti Machine

Prolam's NEW state of the art Optimiser cross cut saw is now installed. Optimizing Cross cut saws are designed for fast and precise cross cutting of single boards. This is massive step forward in Prolam's production capabilities being faster, more précised cutting and overall efficiency gains.

Due to COVID-19, technician's based in Denmark had to provide guidance and instruct the whole install over Zoom and by phone which went smoothly. Check out the quick video of this machine in action.



## BEHIND OUR BRAND: Welcome Lyla McLean



This year we welcomed Lyla McLean to our customer services team. She came fresh from school and dived head first into the busy workforce. She is enjoying her new challenge and loves helping out our customers over the phone. She is also taking on the role of Accounts Payable and plays an important part of our sales and accounts team. In her spare time, Lyla enjoys exploring the great outdoors, caring for animals and has a passion for cars. It has been a pleasure having Lyla in our team, and we look forward to meeting many challenges with her in the future.

## BEHIND OUR BRAND: Meet the Team Video

Prolam would not be where it is today without our awesome and enthusiastic team. Meet some of our amazing team in the video below.



We love hearing from you so if you have any suggestions please contact us on [info@prowoodnz.com](mailto:info@prowoodnz.com).  
We are here to help - 03 526 7436 - [www.prolamnz.com](http://www.prolamnz.com)