

**Building  
better  
together**



# Structural Timber Guide 2026

**Prolam.**  
Posts

**Prolam.**  
PLX20

**Prolam.**  
Beams

**Prolam.**  
PLX Portal

**Prolam.**  
PLX Column

**Prolam.**  
Pergolas

**Prolam.**  
Fascia

**Prolam.**  
Exposed Truss



**Prolam**<sup>®</sup>  
Engineered Laminated Timber

[prolamnz.com](http://prolamnz.com)



## Prolam Product Range

<b>Product Range</b> .....	4
<b>Visual Posts</b> .....	5
<b>Visual Beams</b> .....	7
<b>Non Visual Beams</b> .....	10
<b>Fascia</b> .....	13
<b>PLX20 Beams</b> .....	14
<b>Exposed Truss</b> .....	16
<b>Pergolas</b> .....	17
<b>Finishes</b> .....	18
<b>PLX Portal</b> .....	20
<b>PLX Column</b> .....	22
<b>Prolam Specifier</b> .....	23
<b>Prolam Sizes and Order Codes</b> .....	24
<b>Care and Maintenance</b> .....	28
Specifications .....	29
Durability Statement .....	30
Coating Requirements .....	31
Checking in Prolam .....	32
NZ Timber Design Journal.....	33
<b>Alternative Charts</b> .....	34
<b>Span Tables</b> .....	46
Timber Properties.....	47
Design Data .....	48
Producer Statement.....	48
Lintel supporting roof & ceiling .....	49
Ridge Beam supporting roof & ceiling.....	50
Rafter for internal use supporting roof & ceiling .....	51
Veranda Rafter (wet use) supporting roof without ceiling.....	52

## Proud to be 100% family-owned Kiwi business

Based in the Tasman, with experience spanning more than 20 years, we design, manufacture and supply glulamined timber beams and posts for the residential and commercial building industry across New Zealand.

We hope you find this useful, please don't hesitate to get in touch if have any questions.

Veranda Rafter (wet use) supporting roof and ceiling .....	53
Veranda Lintel (wet use) supporting roof with & without ceiling.....	54
Floor Beam supporting joists .....	55
Floor Joist PL8 .....	56
Floor Joist PL12.....	57
Deck Bearer supporting deck & cantilever.....	58
Deck Joist .....	59
Deck Post Bracing Units.....	60
Veranda/Carport Bracing Post .....	61
Bracing Post Veranda/Carport - free standing supporting roof & ceiling PL8 .....	62
Bracing Post Veranda/Carport - free standing supporting roof & ceiling PL12 .....	63
Bracing Post Veranda/Carport - attached to house supporting roof & ceiling PL8 .....	64
Bracing Post Veranda/Carport - attached to house supporting roof & ceiling PL12 .....	65
Non-Bracing Post - attached to the house supporting veranda roof & ceiling only .....	66
Non-Bracing Post - attached to the house supporting veranda or deck floor only .....	67
Non-Bracing Post - attached to house supporting veranda deck floor & roof ceiling .....	68
<b>Fixings</b> .....	69
Fixing to MCA Timber.....	70
Tapered Ceiling Beam Detail .....	71
Support for Bricks .....	72
Post Fixings .....	73
Corner Post Fixings .....	75
PLX20 Fixings .....	76
<b>Stud Requirement Table</b> .....	78
<b>Holes in Laminated Timber</b> .....	79
<b>FAQs</b> .....	80
<b>Building Product Information</b> .....	85
<b>Licensed Builders Practitioner Details</b> .....	86

# Prolam® Product Range

**Prolam®**  
Posts

**Prolam®**  
PLX20

**Prolam®**  
Pergolas

**Prolam®**  
Beams

**Prolam®**  
Fascia

**Prolam®**  
Exposed Truss

**Prolam®**  
PLX Portal

**Prolam®**  
PLX Column



 **Prolam®**  
Specifier  
Specify with certainty



Scan to learn more

## Visual Posts

**Standard lengths:** 2.4, 2.7, 3.0, 3.6, 4.2, 4.8, 5.4, 6.0, 6.6, 7.2

**Grade:** Visual / Appearance A Finger Jointed

**Structural grade:** PL8 and PL12

**Treatment:** MCA H5 KD

**Finishes:** Machined  
Bandsawn (less 3mm per side)  
Sanded & Sealed  
Pre-Primed  
Square Edge

**Advantages:** H5 Posts Codemark Certified  
Do not need post brackets  
Gives you bracing units (Tables 11&12)  
Structurally Stable  
Superior Fire Resistance  
Good load carrying capacity  
Won't twist or warp  
FSC options available

**Common Uses:** Verandas  
Pergolas  
Fences  
Decks  
Entranceways  
Carports

## Visual/Appearance A H5 KD Posts

PLP – Prolam® Post

CodeMark >>>



Pre-primed Finish

Visual Machine Finish

Bandsawn Finish

Sanded & Sealed Finish

Code	Size
PLPH5-100	88 x 88mm
PLPH5-125	112 x 112mm
PLPH5-150	135 x 135mm
PLPH5-200	180 x 180mm
PLPH5-250	220 x 220mm
PLPH5-300	260 x 260mm
PLPH5-350	300 x 300mm
PLP12H5-100	88 x 88mm
PLP12H5-125	112 x 112mm
PLP12H5-150	135 x 135mm
PLP12H5-200	180 x 180mm
PLP12H5-250	220 x 220mm
PLP12H5-300	260 x 260mm
PLP12H5-350	300 x 300mm

## Visual/Appearance A Beams 88mm

PLVL – Prolam® Visual Lintel

PL8, PL12, H5, H3.2KD, H1.2KD

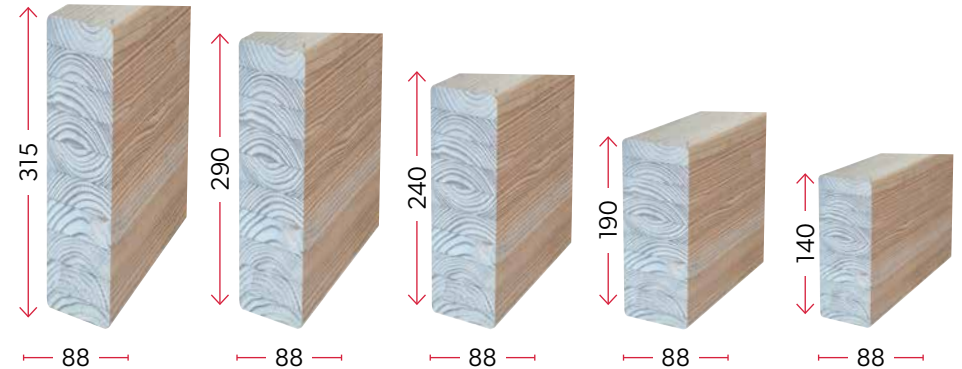

Larger sizes available: 360mm, 405mm, 450mm, 495mm, 540mm, 595mm

Refer to pages 24-27 for product codes.

**Standard lengths:** 3.6, 4.2, 4.8, 5.4, 6.0, 6.6, 7.2 (m) - H3.2 and H1.2

**Other lengths:** 7.8, 8.4, 9.0, 9.6, 10.2, 10.8, 11.4, 12.0 (m) - H3.2/H5 only

**Grade:** Visual / Appearance A Finger Jointed

**Structural grade:** PL8, PL12

**Treatment:** MCA H3.2/H5 KD, H1.2 KD

**Finishes:** Machined  
Sanded & Sealed  
Bandsawn (less 3mm each side)  
Primed

## Visual/Appearance A Beams 63mm

PLVL – Prolam® Visual Lintel  
PL8, PL12, H5KD, H3.2KD, H1.2KD

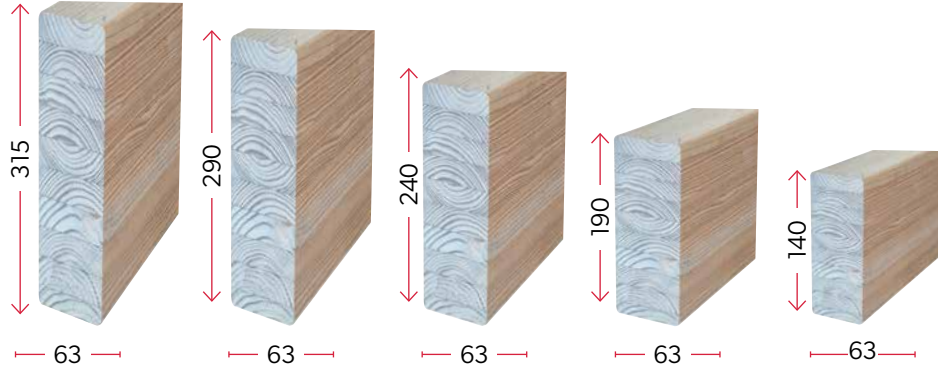

Larger sizes available: 360mm, 405mm, 450mm, 495mm, 540mm, 595mm

Refer to pages 24-27 for product codes.

**Uses:** Veranda Lintels  
Rafters and Beams  
Pergola Beams and Rafters

**Advantages:** Exterior treatment  
Structurally Stable  
Won't twist or warp  
Aesthetically pleasing  
FSC options available

## Visual/Appearance A Beams 42mm

PLVL – Prolam® Visual Lintel  
PL8, PL12, H5KD, H3.2KD, H1.2KD

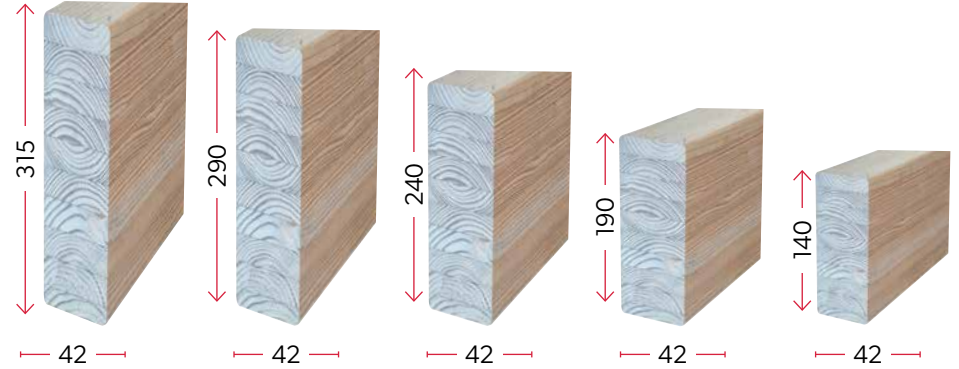

Larger sizes available: 360mm, 405mm, 450mm

Refer to pages 24-27 for product codes.

**Uses:** Veranda Lintels, Rafters and Beams  
Pergola Beams and Rafters  
Deck Joists  
Ceiling Rafters  
Carport Rafters

## Non-Visual Beams 90mm

PL – Prolam® Lintel

PL8, PL12, H5KD, H3.2KD, H1.2KD

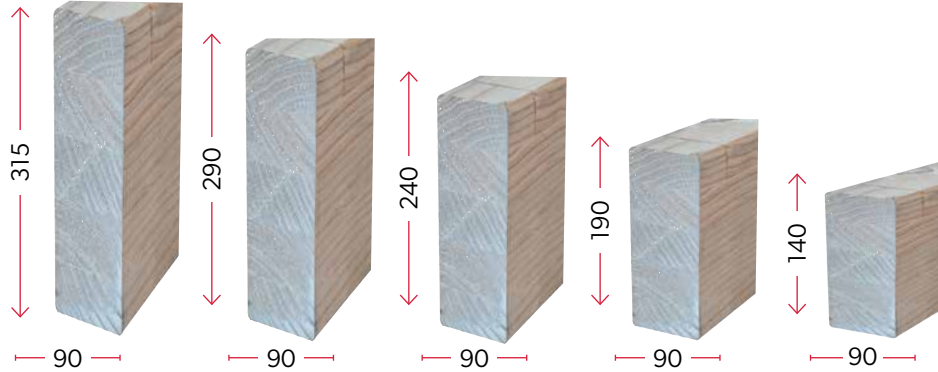

Larger sizes available: 360mm, 405mm, 450mm, 495mm, 540mm, 595mm

Refer to pages 24-27 for product codes.

<b>Standard lengths:</b>	3.6, 4.2, 4.8, 5.4, 6.0, 6.6, 7.2
<b>Grade:</b>	Non-visual, Utility
<b>Structural grade:</b>	PL8 / PL12
<b>Treatment:</b>	MCA H3.2/H5 KD, H1.2 KD
<b>Finishes:</b>	Dressed
<b>Other lengths:</b>	7.8, 8.4, 9.0, 9.6, 10.2, 10.8, 11.4, 12.0 (only in H3.2 NV)
<b>Species:</b>	Radiata, Douglas Fir

All non-visual beams are supplied precambered.

## Non-Visual Beams 63mm

PL – Prolam® Lintel

PL8, PL12, H5KD, H3.2KD, H1.2KD

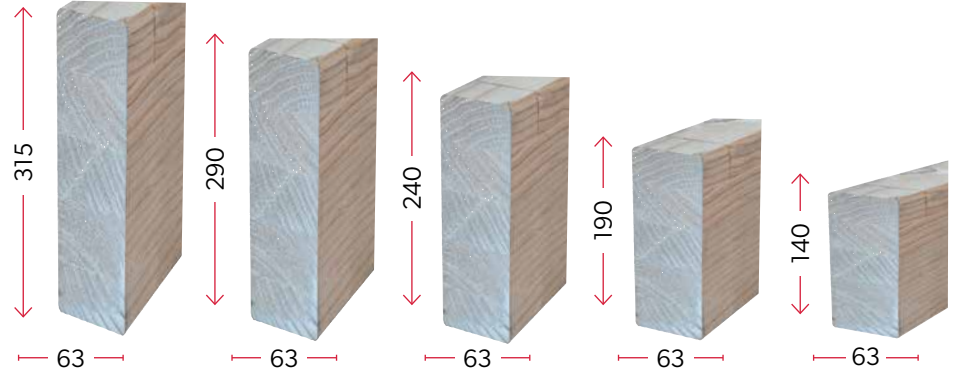

Larger sizes available: 360mm, 405mm, 450mm, 495mm, 540mm, 595mm

Refer to pages 24-27 for product codes.

<b>Uses:</b>	Garage Door Lintels Deck Bearers Deck Joists Floor Joists Rafters Framing Lintels Ridge Beams
--------------	---

All non-visual beams are supplied precambered.

## Non-Visual Beams 42mm

PL – Prolam® Lintel

PL8, PL12, H5KD, H3.2KD, H1.2KD

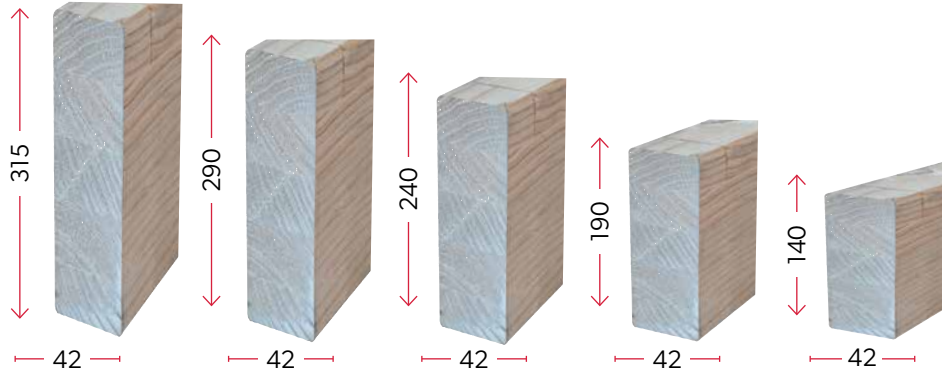

Larger sizes available: 360mm, 405mm, 450mm

Refer to pages 24-27 for product codes.

All non-visual beams are supplied precambered.

## Fascia

H3.2KD



### Custom surface rebate

Fascia Width \_\_\_\_\_  
 Fascia Thickness \_\_\_\_\_  
 Rebate Height \_\_\_\_\_  
 Rebate Width \_\_\_\_\_

<b>Treatment:</b>	MCA H3.2 KD NST
<b>Finish:</b>	Dressed
<b>Lengths:</b>	4.8, 5.4, 6.0m
<b>Other sizes:</b>	Made to order
<b>Advantages:</b>	Exterior treatment Premium finish
<b>Minimum width:</b>	30mm

# Prolam PLX20® Beams

## PLX – Prolam® Hybrid Lintel

### Strength, stability and sustainability

The innovative Prolam PLX20 beam provides superior support for today's build from design to installation. Precision engineered from quality New Zealand pine, the PLX20 has steel laminated in the top and bottom laminates for extra strength and stiffness. It allows a small member beam to span further, making it ideal for garage lintels and other wide structures.

- ▶ High strength and durability for greater spanning.
- ▶ Sustainable option with high timber to steel ratio.
- ▶ Easy to specify using the Prolam Specifier.
- ▶ Competitively priced.
- ▶ Up to 40% lighter than alternatives for fast and easy installation.

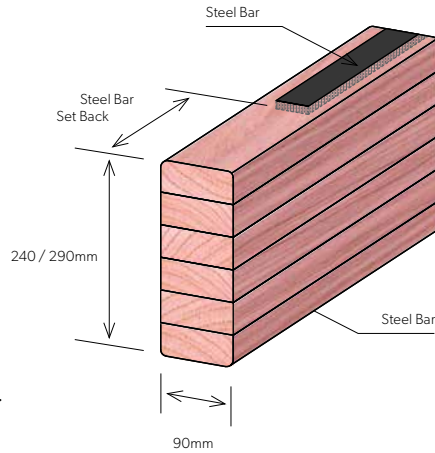

# Prolam PLX20® Beams

- Sizes (mm):** 240x90, 290x90
- Product Code:** PLX20H1-250100, PLX20H1-300100
- Available Lengths:** 3.6, 4.2, 4.8, 5.4, 6.0, 6.6 (m)
- Treatment:** H1.2 KD
- Grade:** Non-Visual
- Species:** Radiata Pine
- Applications:** Lintels, Rafters, Floor beams, Ridge beams

Beam Length (m)	Steel Length (m)	Steel Set Back (mm)
3.6	3.2	200
4.2	3.6	300
4.8	4.2	300
5.4	4.7	350
6.0	5.3	350
6.6	6.0	300

Scan to learn more



### Structural Properties

	Characteristic Strengths (MPa)				Elastic Moduli (MPa)	
	Bending	Tension parallel to grain	Shear in Beam	Compression parallel to grain	Short modulus of elasticity parallel to the grain	Short duration modulus of rigidity for beams
<b>PLX20-250100</b> 240 x 90mm	40	4	3.7	18	20000	480
<b>PLX20-300100</b> 290 x 90mm	45	4	3.7	18	21000	480

- Notes**
1. Intended for use as a beam and not as tension or compression member.
  2. Bending strength and MoE have been determined from testing. Other properties are based on SG6 timber.
  3. Beam design to be in accordance with NZ3603 assuming a timber member using appropriate factors (eg  $\alpha = 0.8$ ).
  4.  $k_2$  factor for creep deflection = 1.25.
  5. Joint group J5 for design of connections.

### Fixing Options

Refer to pages 76-77 for further fixing details.

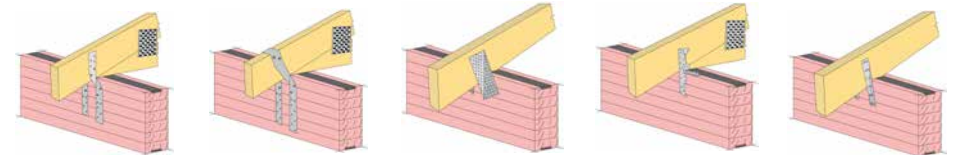

Avoid drilling through or damaging the steel bar for fixings and take care to prevent the steel plate from damaging the screw threads.

All non-visual beams are supplied precambered.



## Exposed Truss

### A stand-out solution inside and out

Prolam Exposed Trusses blend the beauty and strength of timber with the structural integrity and stability of our glulam solution. Our streamlined process, from design to supply, simplifies integration into residential and commercial construction. Choose from standard profiles or customized sizes and designs to match your needs.

- ▶ Premium visual grade structural timber with FSC options available
- ▶ Variety of finishes available
- ▶ H1.2 and H3.2 Treatments available for interior & exterior use
- ▶ Easy to specify with PS1 certification
- ▶ Expert advice from in-house structural engineers
- ▶ High dimensional stability (no twisting or warping)

Scan to learn more



## Pergolas

### Need a Pergola? Think Prolam.

Pergolas enhance the style, depth, and shade of homes and outdoor areas and with Prolam pergolas, the elegance of timber is seamlessly combined with the structural reliability of glulam. Crafting and erecting pergolas with Prolam posts and beams is straightforward and easy thanks to our user-friendly process.

- ▶ PL8 & PL12 structural grades readily available
- ▶ Premium quality and dimensional stability (no twisting or warping)
- ▶ MCA H3.2 & H5 treatment for exterior use
- ▶ Available in a wide range of sizes and lengths
- ▶ Variety of finishes available
- ▶ Expert advice from in-house structural engineers
- ▶ Premium visual grade timber with FSC options available

Scan to learn more



# Prolam® Finishes

## Visual - Appearance A

This grade is intended for use in applications where appearance of the member is important and clear or painted finishes are used. All surface voids are filled, small tight knots are permitted. The surfaces are planer machined to a high quality finish.



## Non-Visual H3.2 - Appearance C

This grade is intended for use in applications where appearance is unimportant. All appearance blemishes are unimportant. All appearance blemishes are permitted in this grade. The surfaces are machined, but machine skip is permissible and blemishes, voids and manufacturing will remain unrepaired. Loose, knots, wane, pith and open knot holes may be present.

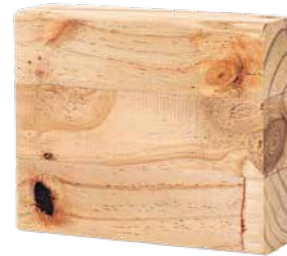

## Non-Visual H1.2 - Appearance C

This grade is intended for use in applications where appearance is unimportant. H1.2 treatment is colour coded pink. All blemishes are permitted in this grade. The surfaces are machined, but skip is permissible, and blemishes, voids and manufacturing will remain unrepaired. Loose knots, wane, pith and open knot holes may be present.



Please email [info@prolamnz.com](mailto:info@prolamnz.com) if you would like to request samples.

## Visual H1.2 - Appearance A

This grade is intended for use in applications where appearance of the member is important and clear or painted finishes are used. All surface voids are filled, small tight knots are permitted. The surfaces are planer machined to a high quality finish. The yellow tint fades quickly.



## Bandsawn

This is only supplied in the visual grade, as it is used for rustic visual appearance, the "roughness" of the bandsawn finish may vary slightly between batches. This product must be sealed as per our sealing specifications.



## Sanded and sealed

This is a premium finish added to a visual product, where all blemishes are filled, the whole product is sanded and then coated with a sealer that will protect the product from ingress of moisture for 6-8 weeks. This sealer is not a long term sealer. The product must be sealed for the long term as per our sealing specifications.



## Preprimed

This is a primary coat that is applied in our factory as a protective coat to stop ingress of moisture until the undercoat and top coats are applied. This primer coat is not to be used as the final finish and the product must be sealed for the long term as per our sealing specifications.



Part of the  
**PLX Bracing**  
range

# Prolam PLX Portal®

## PLX Bracing Portal System

### The next generation in portal bracing is here!

A strong but lightweight timber bracing solution, the PLX Portal is constructed from three glulam timber elements, including the trademarked PLX20 Beam. The reinforced beam offers excellent spanning capability to deliver optimal design flexibility for architectural features ranging from large internal openings to garage and window bracing portals or anywhere you need bracing but only have a narrow wall space.

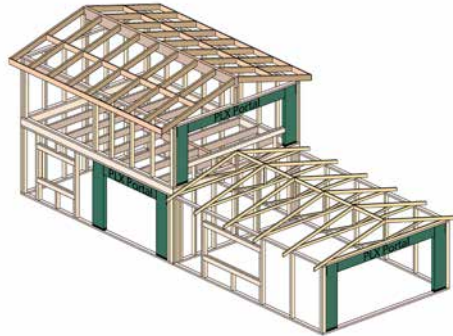

- ▶ High strength and durability.
- ▶ Up to 40% lighter than steel portals.
- ▶ Fast installation – no extra equipment or staff.
- ▶ Better insulation values than steel.
- ▶ Competitively priced.
- ▶ Specify with a free PS1 on the Prolam Specifier.

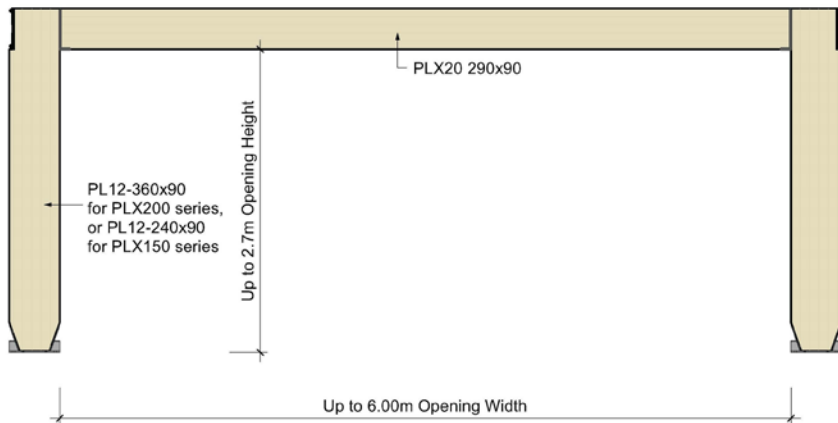

# Prolam PLX Portal®



Scan to  
learn more

### PLX200 Portal Series Bracing Capacity - (Leg Size 360x90mm)

Nominal Stud Height (m)	Max. Opening Height (m)	Max. Opening Width (m)	Wind Bracing (BU's)	Earthquake Bracing (BU's)
2.4	2.2	6.0	184	202
2.7	2.4	6.0	180	199
3.0	2.7	6.0	176	195

### PLX150 Portal Series Bracing Capacity - (Leg Size 240x90mm)

Nominal Stud Height (m)	Max. Opening Height (m)	Max. Opening Width (m)	Wind Bracing (BU's)	Earthquake Bracing (BU's)
2.4	2.2	6.0	108	135
2.7	2.4	6.0	96	120
3.0	2.7	6.0	87	108

Refer to the PLX Portal Design Guide for full bracing capacity charts and product codes.

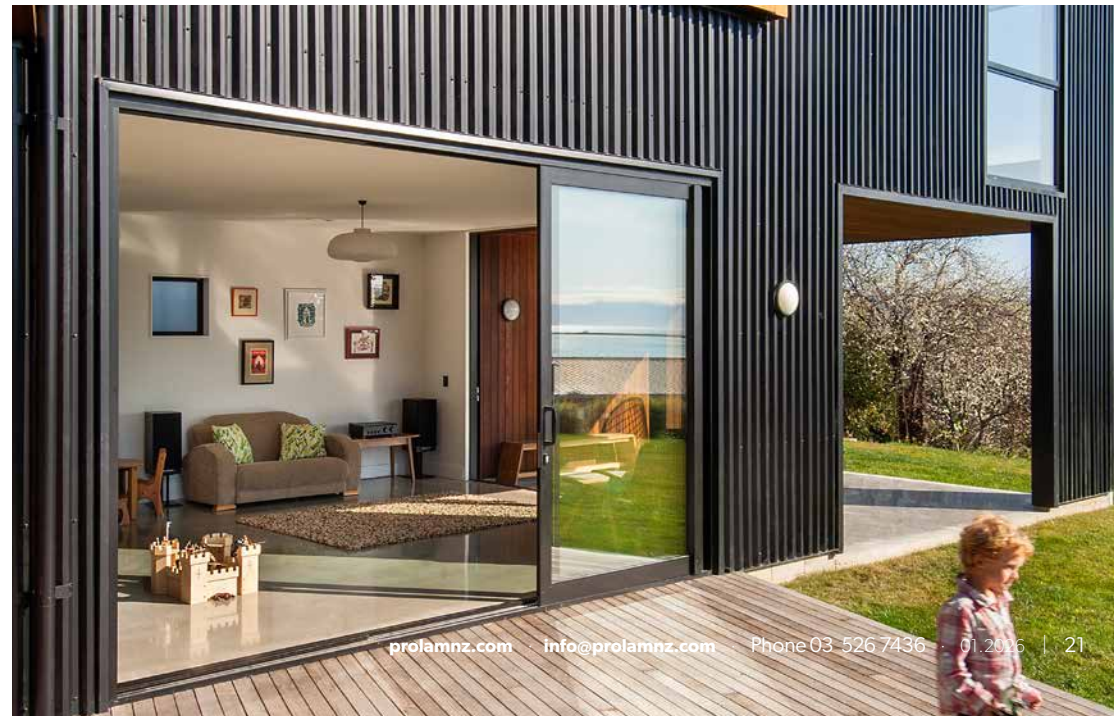



Scan to learn more

Part of the  
**PLX Bracing**  
range

# Prolam PLX Column

## A powerful bracing solution for open-plan designs

Delivering up to 120 bracing units in a single glulam member, the PLX Column is a space-saving, space-making solution for today's homes. Available in 400mm x 90mm or 360mm x 90mm sizes, its compact footprint and high bracing capacity in minimal wall lengths allows you to create wider openings, cleaner lines and more light-filled, liveable interiors. Ideal for open plan living areas, kitchens, entryways, wing walls and large openings.

- ▶ Angled anchors for edges of insulated foundations
- ▶ Delivered as a prefabricated kitset ready to install
- ▶ Cut to length on site for an exact fit
- ▶ Connects easily to timber members (no packing needed)
- ▶ Lightweight and easy to install
- ▶ Simple to specify with a Producer Statement
- ▶ A sustainable choice – made from NZ plantation grown pine
- ▶ NZ-made innovation

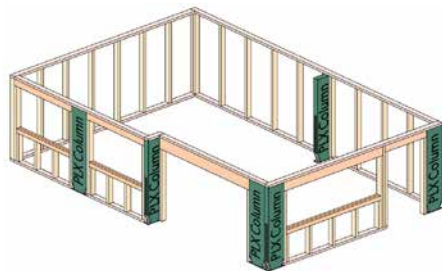
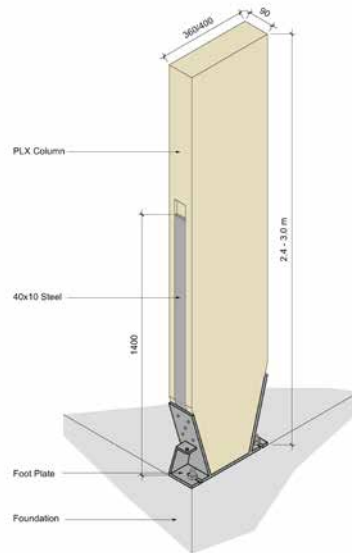

Code	Description	Column Size (mm x mm)	Column Height (m)	Wind BU	Earthquake BU
PLXCH1-400100-2.4H	Prolam PLX Column 360x90 H1.2 2.4H	360 x 90	Up to 2.4	91	103
PLXCH1-400100-2.7H	Prolam PLX Column 360x90 H1.2 2.7H		2.7	81	91
PLXCH1-400100-3.0H	Prolam PLX Column 360x90 H1.2 3.0H		3	73	82
PLXCH1-450100-2.4H	Prolam PLX Column 400x90 H1.2 2.4H	400 x 90	Up to 2.4	116	131
PLXCH1-450100-2.7H	Prolam PLX Column 400x90 H1.2 2.7H		2.7	103	117
PLXCH1-450100-3.0H	Prolam PLX Column 400x90 H1.2 3.0H		3	93	105

# The Prolam® Specifier

## Specify with certainty.

The Prolam Specifier is an efficient and reliable tool for designing structural timber elements. It covers a wide range of most common structural members.

The specifier allows users to effortlessly design members with spans and loaded dimensions beyond the scope of NZS3604.

- ▶ Professionally designed for ultimate user experience
- ▶ Optimized for mobile
- ▶ Clear quality content
- ▶ Training is available
- ▶ Generates PS1 Certificate



Scan to learn more



### Design service and design assistance available for:

- ▶ Exposed trusses
- ▶ Complex beams for Alfresco areas
- ▶ Lintels and posts
- ▶ Bracing portals for Raking portals
- ▶ And more



Scan to learn more

# Prolam Sizes and Order Codes

## Posts Visual - PL8 H5 MCA

Width & Thickness

	88	112	135	180	220	260	300
<b>Code</b>	PLPH5-100	PLPH5-125	PLPH5-150	PLPH5-200	PLPH5-250	PLPH5-300	PLPH5-350

## Posts Visual - PL12 H5 MCA

Width & Thickness

	88	112	135	180	220	260	300
<b>Code</b>	PLP12H5-100	PLP12H5-125	PLP12H5-150	PLP12H5-200	PLP12H5-250	PLP12H5-300	PLP12H5-350

## Beam Visual - PL8 H3.2 MCA

Width & Thickness

	140	190	240	290	315
<b>42 Code</b>	PLVL8H3-15050	PLVL8H3-20050	PLVL8H3-25050	PLVL8H3-30050	PLVL8H3-35050
<b>63 Code</b>	PLVL8H3-15075	PLVL8H3-20075	PLVL8H3-25075	PLVL8H3-30075	PLVL8H3-35075
<b>88 Code</b>	PLVL8H3-150100	PLVL8H3-200100	PLVL8H3-250100	PLVL8H3-300100	PLVL8H3-350100
<b>112 Code</b>	PLVL8H3-150125	PLVL8H3-200125	PLVL8H3-250125	PLVL8H3-300125	PLVL8H3-350125
<b>135 Code</b>	PLVL8H3-150150	PLVL8H3-200150	PLVL8H3-250150	PLVL8H3-300150	PLVL8H3-350150

## Beams Visual - PL12 H3.2 MCA

Width and Thickness

	140	190	240	290	315
<b>42 Code</b>	PLVL12H3-15050	PLVL12H3-20050	PLVL12H3-25050	PLVL12H3-30050	PLVL12H3-35050
<b>63 Code</b>	PLVL12H3-15075	PLVL12H3-20075	PLVL12H3-25075	PLVL12H3-30075	PLVL12H3-35075
<b>88 Code</b>	PLVL12H3-150100	PLVL12H3-200100	PLVL12H3-250100	PLVL12H3-300100	PLVL12H3-350100
<b>112 Code</b>	PLVL12H3-150125	PLVL12H3-200125	PLVL12H3-250125	PLVL12H3-300125	PLVL12H3-350125
<b>135 Code</b>	PLVL12H3-150150	PLVL12H3-200150	PLVL12H3-250150	PLVL12H3-300150	PLVL12H3-350150



## Beam Visual - PL8 H3.2 MCA

Width and Thickness

	360	405	450	495	540	595
<b>Code</b>	PLVL8H3-40050	PLVL8H3-45050	PLVL8H3-50050	PLVL8H3-55050	PLVL8H3-60050	PLVL8H3-65050
<b>Code</b>	PLVL8H3-40075	PLVL8H3-45075	PLVL8H3-50075	PLVL8H3-55075	PLVL8H3-60075	PLVL8H3-65075
<b>Code</b>	PLVL8H3-400100	PLVL8H3-450100	PLVL8H3-500100	PLVL8H3-550100	PLVL8H3-600100	PLVL8H3-650100
<b>Code</b>	PLVL8H3-400125	PLVL8H3-450125	PLVL8H3-500125	PLVL8H3-550125	PLVL8H3-600125	PLVL8H3-650125
<b>Code</b>	PLVL8H3-400150	PLVL8H3-450150	PLVL8H3-500150	PLVL8H3-550150	PLVL8H3-600150	PLVL8H3-650150

## Beams Visual - PL12 H3.2 MCA

Width and Thickness

	360	405	450	495	540	595
<b>Code</b>	PLVL12H3-40050	PLVL12H3-45050	PLVL12H3-50050	PLVL12H3-55050	PLVL12H3-60050	PLVL12H3-65050
<b>Code</b>	PLVL12H3-40075	PLVL12H3-45075	PLVL12H3-50075	PLVL12H3-55075	PLVL12H3-60075	PLVL12H3-65075
<b>Code</b>	PLVL12H3-400100	PLVL12H3-450100	PLVL12H3-500100	PLVL12H3-550100	PLVL12H3-600100	PLVL12H3-650100
<b>Code</b>	PLVL12H3-400125	PLVL12H3-450125	PLVL12H3-500125	PLVL12H3-550125	PLVL12H3-600125	PLVL12H3-650125
<b>Code</b>	PLVL12H3-400150	PLVL12H3-450150	PLVL12H3-500150	PLVL12H3-550150	PLVL12H3-600150	PLVL12H3-650150

### Product codes

Product codes are usually the following sequence (with PLX20 and PLX Portal being exceptions):

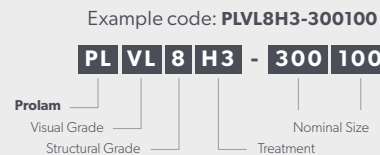

### Product codes

Product codes are usually the following sequence (with PLX20 and PLX Portal being exceptions):

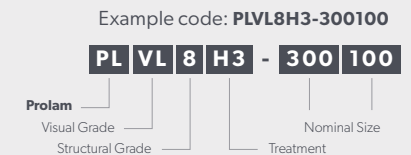

**Beams Non-Visual - PL8 H3.2 MCA**

Width & Thickness

		140	190	240	290	315
42	<b>Code</b>	PL8H3-15050	PL8H3-20050	PL8H3-25050	PL8H3-30050	PL8H3-35050
63	<b>Code</b>	PL8H3-15075	PL8H3-20075	PL8H3-25075	PL8H3-30075	PL8H3-35075
88	<b>Code</b>	PL8H3-150100	PL8H3-200100	PL8H3-250100	PL8H3-300100	PL8H3-350100
112	<b>Code</b>	PL8H3-150125	PL8H3-200125	PL8H3-250125	PL8H3-300125	PL8H3-350125
140	<b>Code</b>	PL8H3-150150	PL8H3-200150	PL8H3-250150	PL8H3-300150	PL8H3-350150

**Non-Visual Beams - PL12 H3.2 MCA**

Width & Thickness

		140	190	240	290	315
42	<b>Code</b>	PL12H3-15050	PL12H3-20050	PL12H3-25050	PL12H3-30050	PL12H3-35050
63	<b>Code</b>	PL12H3-15075	PL12H3-20075	PL12H3-25075	PL12H3-30075	PL12H3-35075
88	<b>Code</b>	PL12H3-150100	PL12H3-200100	PL12H3-250100	PL12H3-300100	PL12H3-350100
112	<b>Code</b>	PL12H3-150125	PL12H3-200125	PL12H3-250125	PL12H3-300125	PL12H3-350125
140	<b>Code</b>	PL12H3-150150	PL12H3-200150	PL12H3-250150	PL12H3-300150	PL12H3-350150

**Non-Visual Beams - PL12 H3.2**

Width and Thickness

		140	190	240	290	315
42	<b>Code</b>	PL8H1-15050	PL8H1-20050	PL8H1-25050	PL8H1-30050	PL8H1-35050
63	<b>Code</b>	PL8H1-15075	PL8H1-20075	PL8H1-25075	PL8H1-30075	PL8H1-35075
88	<b>Code</b>	PL8H1-150100	PL8H1-200100	PL8H1-250100	PL8H1-300100	PL8H1-350100
140	<b>Code</b>	PL8H1-150150	PL8H1-200150	PL8H1-250150	PL8H1-300150	PL8H1-350150

**Non-Visual Beams - PL12 H1.2**

Width and Thickness

		140	190	240	290	315
42	<b>Code</b>	PL12H1-15050	PL12H1-20050	PL12H1-25050	PL12H1-30050	PL12H1-35050
63	<b>Code</b>	PL12H1-15075	PL12H1-20075	PL12H1-25075	PL12H1-30075	PL12H1-35075
88	<b>Code</b>	PL12H1-150100	PL12H1-200100	PL12H1-250100	PL12H1-300100	PL12H1-350100
140	<b>Code</b>	PL12H1-150150	PL12H1-200150	PL12H1-250150	PL12H1-300150	PL12H1-350150

**Product codes**

Product codes are usually the following sequence (with PLX20 and PLX Portal being exceptions):

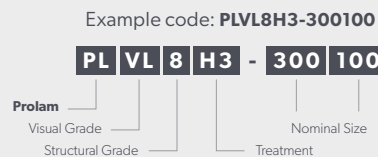

**Beams Non-Visual - PL8 H3.2 MCA**

Width & Thickness

		360	405	450	495	540	595
	<b>Code</b>	PL8H3-40050	PL8H3-45050	PL8H3-50050	PL8H3-55050	PL8H3-60050	PL8H3-65050
	<b>Code</b>	PL8H3-40075	PL8H3-45075	PL8H3-50075	PL8H3-55075	PL8H3-60075	PL8H3-65075
	<b>Code</b>	PL8H3-400100	PL8H3-450100	PL8H3-500100	PL8H3-550100	PL8H3-600100	PL8H3-650100
	<b>Code</b>	PL8H3-400125	PL8H3-450125	PL8H3-500125	PL8H3-550125	PL8H3-600125	PL8H3-650125
	<b>Code</b>	PL8H3-400150	PL8H3-450150	PL8H3-500150	PL8H3-550150	PL8H3-600150	PL8H3-650150

**Non-Visual Beams - PL12 H3.2 MCA**

Width & Thickness

		360	405	450	495	540	595
	<b>Code</b>	PL12H3-40050	PL12H3-45050	PL12H3-50050	PL12H3-55050	PL12H3-60050	PL12H3-65050
	<b>Code</b>	PL12H3-40075	PL12H3-45075	PL12H3-50075	PL12H3-55075	PL12H3-60075	PL12H3-65075
	<b>Code</b>	PL12H3-400100	PL12H3-450100	PL12H3-500100	PL12H3-550100	PL12H3-600100	PL12H3-650100
	<b>Code</b>	PL12H3-400125	PL12H3-450125	PL12H3-500125	PL12H3-550125	PL12H3-600125	PL12H3-650125
	<b>Code</b>	PL12H3-400150	PL12H3-450150	PL12H3-500150	PL12H3-550150	PL12H3-600150	PL12H3-650150

**Non-Visual Beams - PL12 H3.2**

Width and Thickness

		360	405	450	495	540	595
	<b>Code</b>	PL8H1-40050	PL8H1-45050	PL8H1-50050	PL8H1-55050	PL8H1-60050	PL8H1-65050
	<b>Code</b>	PL8H1-40075	PL8H1-45075	PL8H1-50075	PL8H1-55075	PL8H1-60075	PL8H1-65075
	<b>Code</b>	PL8H1-400100	PL8H1-450100	PL8H1-500100	PL8H1-550100	PL8H1-600100	PL8H1-650100
	<b>Code</b>	PL8H1-400150	PL8H1-450150	PL8H1-500150	PL8H1-550150	PL8H1-600150	PL8H1-650150

**Non-Visual Beams - PL12 H1.2**

Width and Thickness

		360	405	450	495	540	595
	<b>Code</b>	PL12H1-40050	PL12H1-45050	PL12H1-50050	PL12H1-55050	PL12H1-60050	PL12H1-65050
	<b>Code</b>	PL12H1-40075	PL12H1-45075	PL12H1-50075	PL12H1-55075	PL12H1-60075	PL12H1-65075
	<b>Code</b>	PL12H1-400100	PL12H1-450100	PL12H1-500100	PL12H1-550100	PL12H1-600100	PL12H1-650100
	<b>Code</b>	PL12H1-400150	PL12H1-450150	PL12H1-500150	PL12H1-550150	PL12H1-600150	PL12H1-650150

**Product codes**

Product codes are usually the following sequence (with PLX20 and PLX Portal being exceptions):

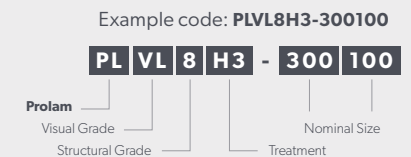

# Care & Maintenance



## Specifications

### Storage and Handling

Storage and handling of Prolam® is the same as any dry timber. As timber naturally absorbs moisture from surrounding environment, exposure to wet weather will dimensionally change the product and cause cracking. The end grain of timber is particularly vulnerable. Stack on level bearers, 150 mm minimum clear of the ground. Store under cover to keep dry prior to installation. Keep unsealed product wrapped. Also refer to Prolam Sealing Specifications.

### Inground Use

When using posts inground, it's recommended the portion of the post that goes in the ground should be sealed to prevent the post taking up moisture and help prevent cracking of the concrete around the post. Also refer to Prolam Sealing Specifications.

### No Substitutions

Substitutions are not permitted to any specified Prolam products or associated components or accessories. The structural properties of other manufactures laminated products may not be comparable.

### Description

Prolam® is engineered, laminated timber with unsurpassed performance, using MCA H5 and H3.2, H1.2 treatments means it can be used in almost any situation. Prolam is made to standards AS/NZS 1328.1 and AS/NZS 1491 and treated to NZS 3640. Using Prolam eliminates the wide variations in solid timber, and allows wide openings to be spanned with ease, along with keeping the lintel depth to a minimum. Prolam is available in many different sizes/grades, meaning there is a beam for every application.

### Design Criteria

Prolam is designed to comply with AS/NZS 1170.0, .1, .2, .3, and .5, structural design actions, NZS3603 Timber Structures, and to comply with the NZBC.



## Durability Statement

Prolam® products are manufactured to the requirements of AS/NZS 1328.1:1998, under an approved quality system based on the ISO 9000 series of standards. As such if the product is used in accordance with Prolam product literature, it will meet the durability clauses of the New Zealand Building Code B2.

### Subfloor Applications

- ▶ Prolam may be used where approved practices for clearance and ventilation are used.

### External Use

- ▶ Prolam is recommended for weather exposed applications if sealed and maintained in accordance with Prolam Sealing Specifications.

### Preservative Treatment

- ▶ Prolam Beams are MCA H3.2 or H1.2 treated as defined by NZS 3640:2011, H3.2 must be used for weather exposed applications, such as Veranda beams, deck bearers, and subfloor applications.
- ▶ Prolam Posts are MCA H5 treated as defined by NZS 3640:2011 for in-ground and weather exposed applications, such as deck piles, Veranda posts and similar applications.

### Storage of Prolam

- ▶ To ensure Prolam remains straight and true at the time of installation, follow the below recommendations:
  1. Store under cover so that it remains dry until installation.
  2. Stack clear of the ground for good ventilation.
  3. Stack on bearers to keep flat and straight.

### Branded Prolam

- ▶ Prolam is branded for your protection. Lookalike materials may not perform to the same standard.
- ▶ For your protection do not accept unauthorized substitution

## Coating requirements

### For Prolam products that are exposed or in-ground

All Prolam products must be coated correctly. This is essential to ensure ongoing performance (durability) as well as maintaining the appearance, where appearance is important. Compliance with all Prolam requirements, including coating requirements, is a condition of our warranty.

### Instructions

These instructions apply where the product is exposed as defined in Figure 4.3(b) of NZS 3604:2011 below.

### Mandatory requirements

For Prolam products that will be exposed to moisture:

- ▶ All exposed surfaces must be fully coated within 14 days of installation.
- ▶ All exposed surfaces, cut ends and joints must be sealed with a good quality stain or alkyd primer. Allow to dry as per manufacturer/supplier instructions.

### For paint:

- Apply a single enamel undercoat and then apply two full topcoats compatible with the undercoat.
- Painting is to be carried out in accordance with best practice: 1 x undercoat and 2 x topcoats to achieve a total DFT (dry film thickness) of 80 microns (comprised of undercoat DFT 30 microns, topcoat DFT 25 microns/coat).
- Prowood recommends only light-coloured paints, but where a dark colour is selected it must have a light reflectance value (LRV) of greater than 45 %.
- Recoating requirements are in accordance with the manufacturer/supplier instructions.

### For stain:

- Apply three coats of premium oil-based stain to all exposed surfaces including cut ends and joints.
- Prowood recommends only light coloured stains.
- Prowood recommends CD50X or Dryden's Penetrating Wood Oil.

### For further information

For our handling and storage requirements and for our warranty refer to: [www.prolamnz.com/technical](http://www.prolamnz.com/technical)

### Optional requirements

For Prolam products where maintenance of the appearance applies:

- ▶ Fill and sand any damage e.g., depressions, temporary fixing holes or unintended transport damage.
- ▶ Holes or large imperfections can be filled with a timber plug using an exterior glue.
- ▶ Sand the product until the surface is smooth and completely free from dirt and dust.
- ▶ Coat as above.

### For Prolam posts that are to be installed in-ground:

It is recommended the in-ground portion of the Prolam post should also be coated before installation to ensure posts do not absorb moisture prior to the concrete curing. Painting as detailed above is recommended.

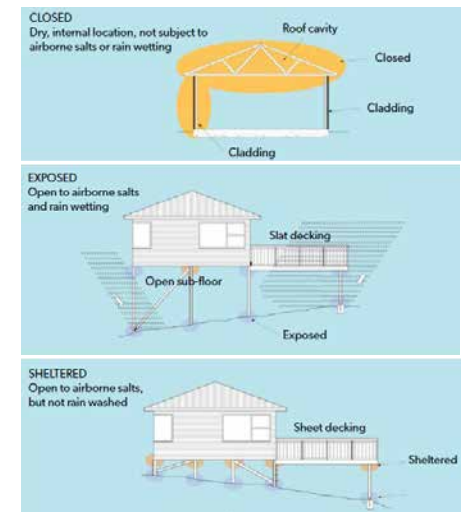

Fig 4.3(a & b) NZS 3604:2011

# Checking in Prolam

One of the advantages of glued laminated timber construction is that while seasoning checks may occur for the same reasons that they do in sawn members, checking in glued laminated timber will generally occur to a much lesser degree because of careful control of the moisture content of timber used for laminating.

Checks in wood are separations along the fibres normally occurring across the rings of annual growth resulting from stresses developed during changes in moisture content. Checks in glued laminated timber may appear as openings parallel to the grain on the sides of members. As wood loses moisture to the surrounding atmosphere, the outer fibres of the member lose moisture at a more rapid rate than do the inner fibres.

As outer fibres try to shrink, they are restrained by the inner portion of the member that has higher moisture content. The more rapid the rate of drying, the greater will be the differential in shrinkage between the outer and inner fibres resulting in higher shrinkage stresses. These resultant stresses perpendicular to the grain of the wood can cause characteristic wood seasoning checks. The influence of checks on the structural

performance of glued laminated timber members is generally minor. Checking can be minimised by careful installation practices that avoid prolonged exposure of the members during construction.

## Identification of Checking

Checks occur as transverse separations or openings that are nearly parallel to the grain direction in glued laminated timber and generally follow the grain direction around knots and along sloping grain.

Differences in the shrinkage rate of individual laminations used is glued laminated timber tend to concentrate shrinkage stresses at or near glue lines, resulting in checks. Checks are often confused with delamination that occurs when the glue bond is not adequate.

The presence of wood fibre separation in these openings is the key distinguishing characteristic of seasoning checks. Openings due to inadequate adhesive bonding may appear as smooth wood surface separations, possibly darkened by the adhesive film, or as glossy surface areas of adhesive with an absence of torn wood fibres.

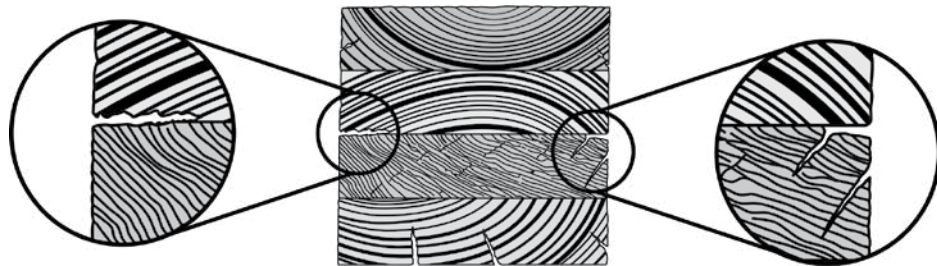

# NZ Timber Design Journal Exposed

## Extract from Issue 2 – Volume 8

It can be assumed that stresses will develop along glue-lines in exposed glulam, simply because the grain orientation, ring orientation, wood density, response to moisture etc. thus will differ between adjacent laminations. European specifications for exposed glulam state that the growth rings in the laminations must all be oriented the same way, and they show a diagram of flat-sawn laminations all with the pith-side downwards.

This is hardly practical in New Zealand with Radiata as the ring orientation is likely to change across a finger joint, and many laminations will be quarter-sawn, flat sawn and everything in between.

Therefore delamination is to be expected but generally should not penetrate more than 20 mm in properly cured glulam, made with resorcinol adhesive. Exposed treated solid timber is likely to develop similar checking. The reason for this is that the moisture fluctuations that give rise to the stresses do not penetrate far, i.e. they are damped out by the resistance of the wood to diffusion of moisture.

Forest Research has tested glulam from a cool store that showed obvious delamination. There appeared to be little effect on strength unless the delamination goes right through. There have been experiments to determine how much delamination can be tolerated before an effect on shear is noticed. Where the glue-line was artificially narrowed by placing adhesive tape along the laminations prior to gluing, there was no effect down to 25%

of the width remaining. When the glued area was reduced by placing adhesive strips across the wood at intervals, an immediate effect was noticed. It all has to do with the stress-raisers generated by the delamination.

Some type of sealing is certainly helpful, and painting is excellent but it must be maintained. An oil-based preservative such as creosote is effective because the oiliness acts as a water repellent. I have seen a thick tacky substance applied to glulam bridge stringers, same as can be applied to steel as a rust preventative.

The bridge in question is at the entrance to the Whakarewarewa village in Rotorua and is still giving good service after 40 years. There are several proprietary formulations of water repellent sealants on the market, and some manufacturers apply "Ensele" as a matter of course.

Written by Bryan Walford, Forest Research Institute, Rotorua



# Alternative Charts



## Alternative to hy90

Prolam® sizes are based on equivalent deflection. These tables are for guidance only, and any Prolam substitution should be verified against the complete selection chart or the Prolam online specifier. [specifier.prolamnz.com](http://specifier.prolamnz.com) Alternatives may not be suitable for all situations.

hy90 E = 9.5GPa	Prolam PL8 Alternative	Prolam PL12 Alternative	Prolam PLX20 * Alternative
150 x 90	190 x 63	140 x 88	-
200 x 90	240 x 63	190 x 88	-
240 x 90	290 x 63	240 x 88	-
300 x 90	360 x 63	290 x 88	240 x 90
360 x 90	405 x 88	360 x 88	290 x 90
400 x 90	450 x 88	405 x 88	-

\* Available in 3.6m, 4.2m, 4.8m, 5.4m, 6.0m lengths

## Alternative to hyONE (LVL16)

Prolam sizes are based on equivalent deflection. These tables are for guidance only, and any Prolam substitution should be verified against the complete selection chart or the Prolam online specifier. [specifier.prolamnz.com](http://specifier.prolamnz.com). Alternatives may not be suitable for all situations.

hyONE E = 16GPa	Prolam PL8 Alternative	Prolam PL12 Alternative	Prolam PLX20 * Alternative
240 x 90	315 x 88	290 x 88	240 x 90
300 x 90	405 x 88	360 x 88	290 x 90
360 x 90	495 x 88	405 x 88	-
400 x 90	540 x 88	450 x 88	-

\* Available in 3.6m, 4.2m, 4.8m, 5.4m, 6.0m lengths

**This table applies only to Prolam products.**

## Alternative to Hyne 17c Glulam

Prolam® sizes are based on equivalent deflection. These tables are for guidance only, and any Prolam substitution should be verified against the complete selection chart or the Prolam online specifier. [specifier.prolamnz.com](http://specifier.prolamnz.com). Alternatives may not be suitable for all situations.

Hyne 17c E = 16.7GPa	Prolam PL8 Alternative	Prolam PL12 Alternative
130 x 65	190 x 63	190 x 42 or 140 x 88
165 x 65	240 x 63 or 190 x 88	190 x 63
195 x 65	240 x 88 or 290 x 42	240 x 63
230 x 65	290 x 88	240 x 88
245 x 65	315 x 63 or 290 x 88	290 x 63
260 x 65	315 x 88	315 x 63 or 290 x 88
295 x 65	360 x 88	315 x 88 or 405 x 42
330 x 65	405 x 88	405 x 63
360 x 65	450 x 88	450 x 63
395 x 65	495 x 88	405 x 88
425 x 65	495 x 88	450 x 88
525 x 65	N/A	540 x 88
295 x 85	405 x 88	360 x 88
330 x 85	450 x 88	405 x 88
360 x 85	495 x 88	405 x 88
425 x 85	540 x 88	495 x 88
460 x 85	595 x 88	540 x 88
525 x 85	N/A	595 x 88

**This table applies only to Prolam products.**

## Alternative to hySPAN or LVL13

Prolam® sizes are based on equivalent deflection. These tables are for guidance only, and any Prolam substitution should be verified against the complete selection chart or the Prolam online specifier. [specifier.prolamnz.com](http://specifier.prolamnz.com). Alternatives may not be suitable for all situations.

hySPAN E = 13.2GPa	Prolam PL8 Alternative	Prolam PL12 Alternative
150 x 45	190 x 42 or 140 x 88	140 x 63
170 x 45	240 x 42 or 190 x 63	190 x 42
200 x 45	240 x 42 or 190 x 88	190 x 63
240 x 45	290 x 42 or 240 x 88	240 x 63
300 x 45	315 x 63 or 290 x 88	290 x 63
360 x 45	360 x 88	360 x 63
400 x 45	405 x 88	405 x 63
150 x 63	190 x 63	140 x 88
170 x 63	190 x 88 or 240 x 42	190 x 63
200 x 63	240 x 63	190 x 88
240 x 63	290 x 63	240 x 88
300 x 63	315 x 88 or 360 x 63	290 x 88
360 x 63	405 x 88 or 450 x 63	360 x 88
400 x 63	450 x 88	405 x 88
600 x 63	N/A	595 x 88
150 x 90	190 x 88	190 x 63
170 x 90	240 x 63	240 x 42
200 x 90	240 x 88	240 x 63
240 x 90	315 x 88	290 x 63
300 x 90	360 x 88	315 x 88
360 x 90	450 x 88	405 x 88
400 x 90	495 x 88	450 x 88

**This table applies only to Prolam products.**

## Alternative to Fitch Beam

Prolam® sizes are based on equivalent deflection. These tables are for guidance only, and any Prolam substitution should be verified against the complete selection chart or the Prolam online specifier. [specifier.prolamnz.com](http://specifier.prolamnz.com). Alternatives may not be suitable for all situations.

Fitch Beam	Prolam PL8 Alternative	Prolam PL12 Alternative	Prolam PLX20 Alternative
FB15L	190 x 63	140 x 90 or 190 x 42	-
FB20M	290 x 90	240 x 90	240 x 90
FB25L	290 x 90	290 x 63	240 x 90
FB25M	360 x 90 or 315 x 112	315 x 90 or 290 x 112	290 x 90
FB30M	405 x 90	360 x 90	290 x 90*

\*PLX20-290x90 is the closest equivalent to FB30M.

## Alternative to Round Poles

Prolam alternatives are intended for small end diameter (SED) round construction poles conforming to the requirements of NZS 3605 for the normal category with a minimum outer zone density of 350 kg/m<sup>3</sup>.

Pole Height (m)	150ø	175ø	200ø	225ø	250ø
2.4	PL8-180	PL8-220 or PL12-180	PL8-220	PL8-260	PL8-300 or PL12-260
3	PL8-180	PL8-220 or PL12-180	PL8-260 or PL12-220	PL8-260	PL8-300 or PL12-260
3.6	PL8-180	PL8-220	PL8-260 or PL12-220	PL8-260	PL8-300 or PL12-260
4.2	PL8-180	PL8-220	PL8-260 or PL12-220	PL8-260	PL8-300 or PL12-260
4.8	PL8-220 or PL12-180	PL8-220	PL8-260 or PL12-220	PL8-260	PL8-300 or PL12-260
5.4	PL8-220 or PL12-180	PL8-220	PL8-260 or PL12-220	PL8-300 or PL12-260	PL8-300
6	PL8-220 or PL12-180	PL8-220	PL8-260 or PL12-220	PL8-300 or PL12-260	PL8-300

**This table applies only to Prolam products.**

## Alternative to LVL11

Prolam® sizes are based on equivalent deflection. These tables are for guidance only, and any Prolam substitution should be verified against the complete selection chart or the Prolam online specifier. [specifier.prolamnz.com](http://specifier.prolamnz.com). Alternatives may not be suitable for all situations.

LVL11 E = 11GPa	Prolam PL8 Alternative	Prolam PL12 Alternative
140 x 45	190 x 42 or 140 x 63	140 x 42
190 x 45	190 x 63 or 240 x 42	190 x 42
200 x 45	240 x 42 or 190 x 88	190 x 63 or 240 x 42
240 x 45	290 x 42 or 240 x 63	240 x 42
300 x 45	315 x 63 or 290 x 88	315 x 42 or 290 x 63
360 x 45	360 x 63	360 x 42
400 x 45	405 x 63	405 x 42
140 x 63	190 x 42	140 x 63
190 x 63	190 x 88 or 240 x 63	190 x 63
200 x 63	240 x 63	190 x 88 or 240 x 42
240 x 63	290 x 63	240 x 63
300 x 63	315 x 88 or 360 x 63	290 x 88 or 315 x 63
360 x 63	360 x 88 or 405 x 63	315 x 88 or 360 x 63
400 x 63	405 x 88	405 x 63
140 x 90	190 x 63	140 x 88
190 x 90	240 x 63	190 x 88
200 x 90	240 x 88	240 x 63
240 x 90	315 x 63	240 x 88 or 290 x 63
300 x 90	360 x 88	315 x 88 or 360 x 63
360 x 90	405 x 88	360 x 88 or 405 x 63
400 x 90	450 x 88	405 x 88

**This table applies only to Prolam products.**

## Alternative to GL13 (includes Hyne LGL)

Prolam® sizes are based on equivalent deflection. These tables are for guidance only, and any Prolam substitution should be verified against the complete selection chart or the Prolam online specifier. [specifier.prolamnz.com](http://specifier.prolamnz.com). Alternatives may not be suitable for all situations.

GL13 E = 13.3GPa	Prolam PL8 Alternative	Prolam PL12 Alternative
140 x 42	190 x 42 or 140 x 88	140 x 63 or 190 x 42
190 x 42	240 x 42 or 190 x 88	190 x 63 or 240 x 42
240 x 42	290 x 42 or 240 x 88	240 x 63 or 290 x 42
290 x 42	315 x 63 or 290 x 88	290 x 63 or 315 x 42
315 x 42	360 x 63 or 290 x 88	290 x 63 or 360 x 42
360 x 42	360 x 88	360 x 63 or 405 x 42
405 x 42	405 x 88	405 x 63
140 x 63	190 x 42	140 x 88 or 190 x 42
190 x 63	240 x 63	190 x 88 or 240 x 63
240 x 63	290 x 63	240 x 88 or 290 x 42
290 x 63	315 x 88	290 x 88 or 315 x 63
315 x 63	360 x 88	315 x 88 or 360 x 63
360 x 63	405 x 88 or 450 x 63	360 x 88 or 405 x 63
405 x 63	450 x 88	405 x 88 or 450 x 63
140 x 90	190 x 63	190 x 42
190 x 90	240 x 88	240 x 63
240 x 90	290 x 88	290 x 63
290 x 90	360 x 88	315 x 88
315 x 90	405 x 88	360 x 88
360 x 90	450 x 88	405 x 88
405 x 90	495 x 88	450 x 88

**This table applies only to Prolam products.**

## Alternative to Hyne15

Prolam® sizes are based on equivalent deflection. These tables are for guidance only, and any Prolam substitution should be verified against the complete selection chart or the Prolam online specifier. [specifier.prolamnz.com](http://specifier.prolamnz.com). Alternatives may not be suitable for all situations.

Hyne15 E 14.8GPa	Prolam PL8 Alternative	Prolam PL12 Alternative	Prolam PLX20
130 x 65	190 x 63	140 x 90	-
165 x 65	190 x 90	190 x 63	-
195 x 65	240 x 63	190 x 90	-
230 x 65	290 x 63	240 x 90	-
260 x 65	290 x 90	290 x 63	240 x 90
295 x 65	360 x 90	290 x 90	240 x 90
330 x 65	405 x 90	360 x 63	290 x 90
360 x 65	450 x 63 or 405 x 90	405 x 63 or 360 x 90	290 x 90
395 x 65	495 x 63 or 450 x 90	450 x 63 or 405 x 90	-
425 x 65	540 x 63 or 495 x 90	450 x 90	-
460 x 65	595 x 63 or 540 x 90	450 x 90	-
495 x 65	595 x 90	495 x 90	-
230 x 85	290 x 90	290 x 63	240 x 90
260 x 85	315 x 90	290 x 90	240 x 90
295 x 85	360 x 90	315 x 90	290 x 90
330 x 85	405 x 90	360 x 90	290 x 90
360 x 85	450 x 90	405 x 90	-
395 x 85	495 x 90	450 x 90	-
425 x 85	595 x 63 or 540 x 90	540 x 63 or 495 x 90	-
460 x 85	595 x 90	495 x 90	-
495 x 85	-	595 x 63 or 540 x 90	-
525 x 85	-	595 x 90	-

**This table applies only to Prolam products.**

## Alternative to SG8

Prolam® sizes are based on equivalent deflection. These tables are for guidance only, and any Prolam substitution should be verified against the complete selection chart or the Prolam online specifier. [specifier.prolamnz.com](http://specifier.prolamnz.com). Alternatives may not be suitable for all situations.

SG8	Prolam PL8 Alternative	Prolam PL12 Alternative
140 x 45*	140 x 42	140 x 42 or 90 x 90
190 x 45*	190 x 42 or 140 x 90	190 x 42 or 140 x 63
240 x 45*	240 x 42 or 190 x 63	190 x 42
290 x 45*	290 x 42 or 240 x 63	240 x 42 or 190 x 90
140 x 70**	140 x 63	140 x 42
190 x 70**	190 x 63	190 x 42
240 x 70**	240 x 63	240 x 42
290 x 70**	290 x 63	290 x 42
140 x 90**	190 x 42 or 140 x 90	140 x 63
190 x 90**	240 x 42 or 190 x 93	190 x 63
240 x 90**	240 x 90	240 x 63
290 x 90**	290 x 90	290 x 63

\*One Member  $E_{lb} = 5.4 \text{ GPa}$

\*\*Two Members  $E = 6.7 \text{ GPa}$

**This table applies only to Prolam products.**

## Comparison with hyJOISTS Domestic Floors

### 1.5kPa Live load SINGLE SPAN

Prolam® sizes are based on equivalent deflection. These tables are for guidance only, and any Prolam substitution should be verified against the complete selection chart or the Prolam online specifier. [specifier.prolamnz.com](http://specifier.prolamnz.com). Alternatives may not be suitable for all situations.

hyJOIST	Joist Spacing	Span Range	Prolam Equivalent			
			Joist size	Spacing	Grade	Max Span
HJ200 45	450	3.5 to 3.8	190x63	450	PL8	3.6
			240x42	450	PL8	4.1
			190x42	450	PL12	3.5
HJ200 45	600	3.1 to 3.6	190x63	600	PL8	3.6
			240x42	600	PL8	4.0
			190x42	600	PL12	3.5
HJ240 63	450	4.4 to 4.9	240x63	450	PL8	4.7
			290x42	450	PL8	4.9
			240x42	450	PL12	4.6
HJ240 63	600	4.0 to 4.5	240x63	600	PL8	4.6
			290x42	600	PL8	4.8
			240x42	600	PL12	4.5
HJ240 90	450	4.9 to 5.4	290x63	450	PL8	5.7
			315x42	450	PL8	5.4
			240x63	450	PL12	5.3
HJ240 90	600	4.5 to 5.0	290x63	600	PL8	5.6
			315x42	600	PL8	5.3
			240x63	600	PL12	5.2
			290x42	600	PL12	5.5

**This table applies only to Prolam products.**

## Comparison with hyJOISTS - Continued Domestic Floors

### 1.5kPa Live load SINGLE SPAN

Prolam® sizes are based on equivalent deflection. These tables are for guidance only, and any Prolam substitution should be verified against the complete selection chart or the Prolam online specifier. [specifier.prolamnz.com](http://specifier.prolamnz.com). Alternatives may not be suitable for all situations.

hyJOIST	Joist Spacing	Span Range	Prolam Equivalent			
			Joist size	Spacing	Grade	Max Span
<b>HJ300 63</b>	450	5.0 to 5.5	290x63	450	PL8	5.7
			315x42	450	PL8	5.4
			240x63	450	PL12	5.3
			290x42	450	PL12	5.6
<b>HJ300 63</b>	600	4.6 to 5.1	290x63	600	PL8	5.6
			315x42	600	PL8	5.3
			240x63	600	PL12	5.2
			290x42	600	PL12	5.5
<b>HJ300 90</b>	450	5.6 to 6.1	315x63	450	PL8	6.2
			360x42	450	PL8	6.2
			290x63	450	PL12	6.4
			315x42	400	PL12	6.1
<b>HJ300 90</b>	600	5.2 to 5.7	315x63	600	PL8	6.0
			360x42	600	PL8	5.9
			290x63	600	PL12	6.1
			315x42	600	PL12	5.9
<b>HJ360 63</b>	450	5.6 to 6.2	315x63	450	PL8	6.2
			360x42	450	PL8	6.2
			290x63	450	PL12	6.4
			315x42	450	PL12	6.1
<b>HJ360 63</b>	600	5.2 to 5.7	315x63	600	PL8	6.0
			360x42	600	PL8	5.9
			290x63	600	PL12	6.1
			315x42	600	PL12	5.9

**This table applies only to Prolam products.**

## Comparison with hyJOISTS - Continued Domestic Floors

### 1.5kPa Live load SINGLE SPAN

Prolam® sizes are based on equivalent deflection. These tables are for guidance only, and any Prolam substitution should be verified against the complete selection chart or the Prolam online specifier. [specifier.prolamnz.com](http://specifier.prolamnz.com). Alternatives may not be suitable for all situations.

hyJOIST	Joist Spacing	Span Range	Prolam Equivalent			
			Joist size	Spacing	Grade	Max Span
<b>HJ360 90</b>	450	6.3 to 6.8	360x63	450	PL8	7.1
			405x42	450	PL8	6.9
			315x63	450	PL12	7.0
			360x42	450	PL12	7.0
<b>HJ360 90</b>	600	5.8 to 6.3	360x63	600	PL8	6.6
			405x42	600	PL8	6.5
			315x63	600	PL12	6.5
			360x42	600	PL12	6.5
<b>HJ400 90</b>	450	6.8 to 7.2	405x63	450	PL8	7.8
			360x63	450	PL12	7.8
			405x42	450	PL12	7.7
<b>HJ400 90</b>	600	6.3 to 6.7	405x63	600	PL8	7.2
			360x63	600	PL12	7.2
			405x42	600	PL12	7.1

**This table applies only to Prolam products.**

# Span Tables



## Timber properties

Used in span table calculations

### Dry Use

Characteristic Stresses and Elastic Moduli for Prolam (Glulam Grades)

	Characteristic Strengths (MPa)					Elastic Moduli (MPa)	
	PL Grade	Bending	Tension parallel to grain	Shear in Beam	Compression parallel to grain	Modulus of elasticity parallel to the grain	Modulus of rigidity for beams
Prolam	PL 12	25	12.5	3.7	29	11500	770
Prolam	PL 8	19	10	3.7	24	8000	530
Prolam	PLX20	40†/45‡	4	3.7	18	20000†/21000‡	480

† PLX20-250100

‡ PLX20-300100

- Notes**
- (1) PLX20 intended for use as a beam and not as a tension or compression member.
  - (2) PLX20 bending strength and MoE about the major axis have been determined from testing. Other properties are based on SG6 timber.
  - (3) For compression perpendicular to the grain, use 8.9 MPa dry and 5.3 MPa wet as per NZS 3603 for Radiata Pine for all PL grades.
  - (4) Higher grades (i.e. PL12, or PLX20) will give greater span and load carrying capability than PL8 for the same section size.

### Wet Use – (H5 & H3.2 treated)

Characteristic Stresses and Elastic Moduli for Prolam (Glulam Grades)

PL Grade	Characteristic Strengths (MPa)				Elastic Moduli (MPa)	
	Bending	Tension parallel to grain	Shear in Beam	Compression parallel to grain	Modulus of elasticity parallel to the grain	Modulus of rigidity for beams
PL 12	20	10	2.5	23.2	9200	610
PL 8	15.2	8.0	2.5	19.2	6400	420

### Design Data

The tables herein have been designed according to the following loads:

Roof				
Dead Load		Live Load	Snow Load	Wind Load
Lighweight Roof	Ceiling	0.25 kPa Uniform	0.4kPa	High Wind (NZS3604:2011)
0.25 kPa	0.15 kPa	1.1 kN point load		

Floor			
Domestic Floor		Deck	
Dead Load	Live Load	Dead Load	Live Load
0.40 kPa	1.5 kPa Uniform	0.40 kPa	2 kPa Uniform
	1.80 kN Point Load		1.80 kN Point Load

Deflection Limits	
Lintel	Span / 300 or 12mm
Rafter	Span / 300 or 25mm
Bearer	Span / 300 or 12mm
Joist	Span / 350 or 20mm

- Notes**
- 750mm eaves width has been included in the derivation of the tables.
  - Spans are horizontal measurements. For heavy roofs or over 25° pitch roofs, use the Prolam® specifier.
  - The span tables in this booklet do not apply to the bandsawn product. Use the Prolam® Specifier.

November 2022

## PRODUCER STATEMENT

Tasman Consulting Engineers Ltd have been engaged by Prowood to prepare span tables and charts for the Prolam® lintels, beams and posts as presented in the Prolam® Post and Beam Manual.

The design has been carried out using sound and widely accepted engineering principles to the requirements of AS/NZS1170:2002, NZS3603:1993 and NZS3604:2011 using the timber properties for PL8 and PL12 glue laminated timber.



Tasman Consulting Engineers Limited  
195 Queen St, PO Box 3631  
Richmond, NELSON 7050

*David King*

ME(Civil) CMEngNZ (No.145511) CPEng IntPE

### Span Tables

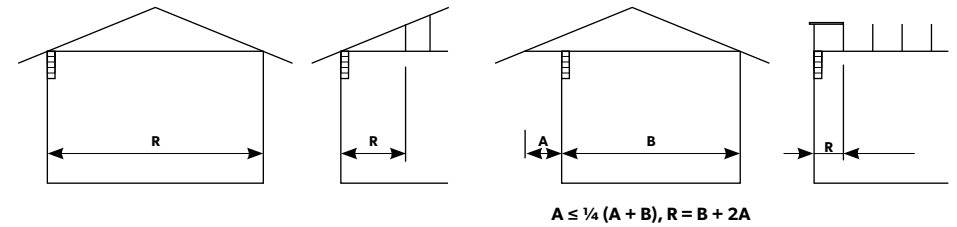

**Table 1**  
Prolam® Lintel supporting roof and ceiling

		Roof Span (m) 'R'	2.0	3.0	4.0	5.0	6.0	7.0	8.0	9.0	10.0	11.0	12.0
		Lintel Size	Maximum Lintel Span (m)										
<b>PL8</b>	<b>Light Roof</b>	<b>PL8H1-150100</b> 140 x 90mm	2.9	2.7	2.6	2.5	2.4	2.3	2.2	2.1	2.0	1.9	1.9
		<b>PL8H1-200100</b> 190 x 90mm	3.7	3.4	3.3	3.1	3.0	2.9	2.8	2.8	2.7	2.6	2.5
		<b>PL8H1-250100</b> 240 x 90mm	4.4	4.1	3.9	3.7	3.6	3.5	3.4	3.3	3.2	3.2	3.1
		<b>PL8H1-300100</b> 290 x 90mm	5.1	4.8	4.5	4.3	4.2	4.0	3.9	3.8	3.7	3.7	3.6
		<b>PL8H1-350100</b> 315 x 90mm	5.4	5.1	4.8	4.6	4.4	4.3	4.2	4.1	4.0	3.9	3.8
		<b>PL8H1-400100</b> 360 x 90mm	6.0	5.6	5.3	5.1	4.9	4.8	4.6	4.5	4.4	4.4	4.2
<b>PL12</b>	<b>Light Roof</b>	<b>PL12H1-150100</b> 140 x 90mm	3.2	3.0	2.8	2.7	2.6	2.5	2.5	2.4	2.3	2.2	2.1
		<b>PL12H1-200100</b> 190 x 90mm	4.0	3.8	3.6	3.4	3.3	3.2	3.1	3.0	3.0	2.9	2.9
		<b>PL12H1-250100</b> 240 x 90mm	4.8	4.5	4.3	4.1	4.0	3.8	3.7	3.6	3.6	3.5	3.4
		<b>PL12H1-300100</b> 290 x 90mm	5.6	5.2	5.0	4.7	4.6	4.4	4.3	4.2	4.1	4.0	3.9
		<b>PL12H1-350100</b> 315 x 90mm	5.9	5.5	5.3	5.1	4.9	4.7	4.6	4.5	4.4	4.3	4.2
		<b>PL12H1-400100</b> 360 x 90mm	6.5	6.1	5.8	5.6	5.4	5.2	5.1	5.0	4.8	4.7	4.6

**Note** The design parameters are specified in the design data page.  
For different parameters, refer to Prolam Online Specifier at [specifier.prolamnz.com](http://specifier.prolamnz.com)

**This table applies only to Prolam products.**

### Span Tables

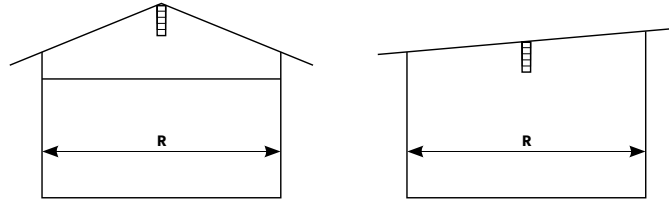

**Table 2**

**Prolam® Ridge Beam** supporting roof and ceiling. (Rafters at 1200mm CRS MAX)

Roof Span (m) 'R'		2.0	3.0	4.0	5.0	6.0	7.0	8.0	9.0	10.0	11.0	12.0
Ridge Beam Size		Maximum Ridge Beam Span (m)										
PL8	PL8H1-150100 140 x 90mm	3.2	3.0	2.8	2.7	2.5	2.4	2.4	2.3	2.2	2.1	2.0
	PL8H1-200100 190 x 90mm	4.2	3.8	3.5	3.4	3.2	3.1	3.0	2.9	2.8	2.7	2.7
	PL8H1-250100 240 x 90mm	5.0	4.6	4.2	4.0	3.8	3.7	3.6	3.4	3.4	3.3	3.2
	PL8H1-300100 290 x 90mm	5.8	5.3	4.9	4.6	4.4	4.2	4.1	4.0	3.9	3.8	3.7
	PL8H1-35000 315 x 90mm	6.2	5.6	5.2	4.9	4.7	4.5	4.4	4.2	4.1	4.0	3.9
	PL8H1-400100 360 x 90mm	6.8	6.2	5.8	5.5	5.2	5.0	4.8	4.7	4.6	4.5	4.3
PL12	PL12H1-150100 140 x 90mm	3.6	3.3	3.1	2.9	2.8	2.7	2.6	2.5	2.4	2.4	2.3
	PL12H1-200100 190 x 90mm	4.6	4.2	3.9	3.7	3.5	3.4	3.3	3.2	3.1	3.0	2.9
	PL12H1-250100 240 x 90mm	5.5	5.0	4.6	4.4	4.2	4.0	3.9	3.8	3.7	3.6	3.5
	PL12H1-300100 290 x 90mm	6.4	5.8	5.4	5.1	4.8	4.7	4.5	4.4	4.3	4.2	4.1
	PL12H1-350100 315 x 90mm	6.7	6.1	5.7	5.4	5.2	5.0	4.8	4.7	4.5	4.4	4.3
	PL12H1-400100 360 x 90mm	7.4	6.8	6.3	6.0	5.7	5.5	5.3	5.2	5.0	4.9	4.8

**Note** The design parameters are specified in the design data page.  
For different parameters, refer to Prolam Online Specifier at [specifier.prolamnz.com](http://specifier.prolamnz.com)

**This table applies only to Prolam products.**

### Span Tables

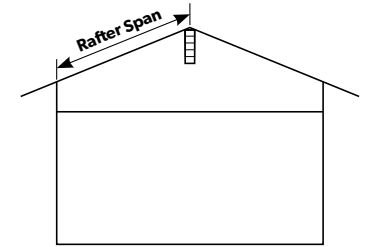

**Table 3**

**Prolam® Rafter** for internal use supporting roof and ceiling

Rafter Spacing (m)	0.6	0.75	0.9	1.0	1.2	Rafter Spacing (m)	0.6	0.75	0.9	1.0	1.2
Rafter Size	Maximum Rafter Span (m)					Rafter Size	Maximum Rafter Span (m)				
PLVL8H3-15075 140 x 63mm	3.3	3.0	2.9	2.8	2.6	PLVL8H3-15050 140 x 42mm	2.6	2.5	2.4	2.4	2.3
	B	B	B	B	B		B	B	B	B	B
PLVL8H3-20075 190 x 63mm	4.4	4.1	3.9	3.8	3.6	PLVL8H3-20050 190 x 42mm	3.9	3.6	3.5	3.3	3.2
	B	B	B	B	B		B	B	B	B	B
PLVL8H3-25075 240 x 63mm	5.4	5.1	4.9	4.7	4.5	PLVL8H3-25050 240 x 42mm	4.9	4.6	4.3	4.2	4.0
	B	B	B	B	B		B	B	B	B	B
PLVL8H3-30075 290 x 63mm	6.5	6.1	5.8	5.7	5.4	PLVL8H3-30050 290 x 42mm	5.8	5.5	5.2	5.1	4.8
	B	B	B	B	B		B	B	B	B	B
PLVL8H3-35075 315 x 63mm	6.9	6.6	6.3	6.1	5.8	PLVL8H3-35050 315 x 42mm	6.3	5.9	5.6	5.5	5.2
	B	B	B	B	B		B	B	B	B	B
PLVL8H3-40075 360 x 63mm	7.5	7.3	7.0	6.9	6.6	PLVL8H3-40050 360 x 42mm	7.0	6.7	6.4	6.2	5.9
	B	B	B	B	C		B	B	B	B	C

**Fixing type**

B 2/100 x 3.75 skewed nails and 1 wire dog or 2.7kN connection  
 C 2/100 x 3.75 skewed nails and 2 wire dog or 4.7kN connection  
 End fixing to resist uplift – refer also to NZS3604: 2011

**Note** The design parameters are specified in the design data page.  
For different parameters, refer to Prolam Online Specifier at [specifier.prolamnz.com](http://specifier.prolamnz.com)

**This table applies only to Prolam products.**

Span Tables

**Table 4**  
Prolam® Veranda Rafter (wet use) supporting roof without ceiling

Rafter Spacing (m)	0.6	0.75	0.9	1.0	1.2
Rafter Size	Maximum Rafter Span (m)				
PLVL8H3-10050 88 x 42mm	1.0	1.0	1.0	0.9	0.9
	B	B	B	B	B
PLVL8H3-15050 140 x 42mm	2.3	2.2	2.2	2.2	2.1
	B	B	B	B	B
PLVL8H3-20050 190 x 42mm	3.7	3.5	3.4	3.4	3.2
	B	B	B	B	B
PLVL8H3-25050 240 x 42mm	4.9	4.7	4.6	4.5	4.2
	B	B	B	B	B
PLVL8H3-30050 290 x 42mm	6.1	5.8	5.5	5.3	5.1
	B	B	B	B	C
PLVL8H3-35050 315 x 42mm	6.6	6.2	5.9	5.8	5.5
	B	B	B	C	C
PLVL8H3-40050 360 x 42mm	7.2	6.9	6.6	6.4	6.1
	B	B	C	C	C

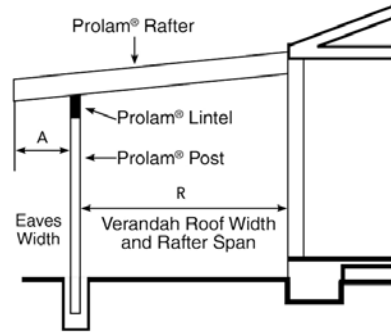

**Fixing type**  
 B 2/100 x 3.75 skewed nails and 1 wire dog or 2.7kN connection  
 C 2/100 x 3.75 skewed nails and 2 wire dog or 4.7kN connection  
 End fixing to resist uplift - Refer also to NZS3604:2011

Rafter Spacing (m)	0.6	0.75	0.9	1.0	1.2
Rafter Size	Maximum Rafter Span (m)				
PLVL8H3-10075 88 x 63mm	1.5	1.4	1.4	1.4	1.4
	B	B	B	B	B
PLVL8H3-15075 140 x 63mm	3.3	3.2	3.1	3.0	2.8
	B	B	B	B	B
PLVL8H3-20075 190 x 63mm	4.5	4.3	4.1	4.0	3.8
	B	B	B	B	B
PLVL8H3-25075 240 x 63mm	5.6	5.3	5.1	5.0	4.7
	B	B	B	B	B
PLVL8H3-30075 290 x 63mm	6.6	6.3	6.1	5.9	5.7
	B	B	B	B	C
PLVL8H3-35075 315 x 63mm	7.0	6.8	6.6	6.4	6.1
	B	B	B	C	C
PLVL8H3-40075 360 x 63mm	7.7	7.4	7.2	7.1	6.8
	B	B	C	C	C

**Note** The design parameters are specified in the design data page. For different parameters, refer to Prolam Online Specifier at [specifier.prolamnz.com](http://specifier.prolamnz.com)

This table applies only to Prolam products.

Span Tables

**Table 5**  
Prolam® Veranda Rafter (wet use) supporting roof and ceiling

Rafter Spacing (m)	0.6	0.75	0.9	1.0	1.2
Rafter Size	Maximum Rafter Span (m)				
PLVL8H3-10050 88 x 42mm	0.9	0.9	0.9	0.8	0.8
	B	B	B	B	B
PLVL8H3-15050 140 x 42mm	2.1	2.0	2.0	1.9	1.9
	B	B	B	B	B
PLVL8H3-20050 190 x 42mm	3.3	3.2	3.1	3.0	2.8
	B	B	B	B	B
PLVL8H3-25050 240 x 42mm	4.5	4.2	4.0	3.8	3.6
	B	B	B	B	B
PLVL8H3-30050 290 x 42mm	5.4	5.0	4.8	4.6	4.4
	B	B	B	B	B
PLVL8H3-35050 315 x 42mm	5.8	5.5	5.2	5.0	4.8
	B	B	B	B	B
PLVL8H3-40050 360 x 42mm	6.6	6.2	5.9	5.7	5.4
	B	B	B	B	B

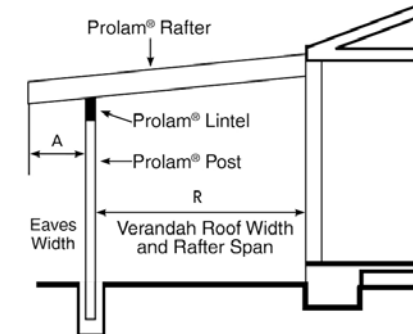

**Fixing type**  
 B 2/100 x 3.75 skewed nails and 1 wire dog or 2.7kN connection  
 C 2/100 x 3.75 skewed nails and 2 wire dogs or 4.7kN connection  
 End fixing to resist uplift - Refer also to NZS3604: 2011

Rafter Spacing (m)	0.6	0.75	0.9	1.0	1.2
Rafter Size	Maximum Rafter Span (m)				
PLVL8H3-10075 88 x 63mm	1.4	1.4	1.3	1.3	1.3
	B	B	B	B	B
PLVL8H3-15075 140 x 63mm	3.0	2.8	2.7	2.6	2.4
	B	B	B	B	B
PLVL8H3-20075 190 x 63mm	4.0	3.8	3.6	3.5	3.3
	B	B	B	B	B
PLVL8H3-25075 240 x 63mm	5.0	4.7	4.5	4.4	4.2
	B	B	B	B	B
PLVL8H3-30075 290 x 63mm	6.0	5.7	5.4	5.3	5.0
	B	B	B	B	B
PLVL8H3-35075 315 x 63mm	6.5	6.1	5.8	5.7	5.4
	B	B	B	B	B
PLVL8H3-40075 360 x 63mm	7.1	6.9	6.6	6.4	6.1
	B	B	B	B	C

**Note** The design parameters are specified in the design data page. For different parameters, refer to Prolam Online Specifier at [specifier.prolamnz.com](http://specifier.prolamnz.com)

This table applies only to Prolam products.

Rafter Spacing (m)	0.6	0.75	0.9	1.0	1.2
Rafter Size	Maximum Rafter Span (m)				
PLVL8H3-100100 88 x 88mm	2.0	1.9	1.9	1.9	1.8
	B	B	B	B	B
PLVL8H3-150100 140 x 88mm	3.7	3.5	3.4	3.3	3.1
	B	B	B	B	B
PLVL8H3-200100 190 x 88mm	4.9	4.7	4.5	4.4	4.2
	B	B	B	B	B
PLVL8H3-250100 240 x 88mm	6.0	5.8	5.5	5.4	5.2
	B	B	B	B	C
PLVL8H3-300100 290 x 88mm	7.0	6.8	6.5	6.4	6.1
	B	B	B	C	C
PLVL8H3-350100 315 x 88mm	7.3	7.1	6.9	6.8	6.6
	B	B	B	C	C
PLVL8H3-400100 360 x 88mm	8.0	7.8	7.6	7.5	7.3
	B	B	C	C	C

Rafter Spacing (m)	0.6	0.75	0.9	1.0	1.2
Rafter Size	Maximum Rafter Span (m)				
PLVL8H3-100100 88 x 88mm	1.9	1.8	1.8	1.7	1.7
	B	B	B	B	B
PLVL8H3-150100 140 x 88mm	3.3	3.1	2.9	2.9	2.7
	B	B	B	B	B
PLVL8H3-200100 190 x 88mm	4.4	4.2	4.0	3.8	3.7
	B	B	B	B	B
PLVL8H3-250100 240 x 88mm	5.4	5.2	4.9	4.8	4.6
	B	B	B	B	B
PLVL8H3-300100 290 x 88mm	6.5	6.1	5.9	5.7	5.5
	B	B	B	B	B
PLVL8H3-350100 315 x 88mm	6.9	6.6	6.4	6.2	5.9
	B	B	B	B	B
PLVL8H3-400100 360 x 88mm	7.5	7.3	7.0	6.9	6.7
	B	B	B	B	C

Span Tables

Table 6

Prolam® Veranda Lintel (wet use) supporting roof with and without ceiling

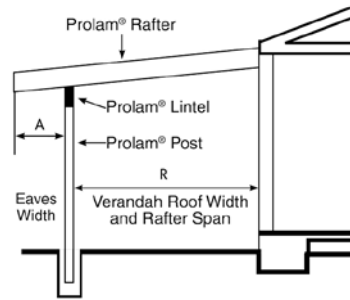

		Roof Width (m) 'R'										
		1.2	1.8	2.4	3.0	3.6	4.2	4.8	5.4	6.0	6.6	
Lintel Size		Maximum lintel span (m)										
No Ceiling	PLVL8H3-15075 140 x 63mm	2.7	2.5	2.4	2.3	2.3	2.2	2.1	2.1	2.0	2.0	
	PLVL8H3-20075 190 x 63mm	3.4	3.2	3.1	3.0	2.9	2.8	2.7	2.7	2.6	2.5	
	PLVL8H3-25075 240 x 63mm	4.0	3.8	3.7	3.5	3.4	3.3	3.3	3.2	3.1	3.1	
	PLVL8H3-30075 290 x 63mm	4.7	4.4	4.2	4.1	4.0	3.9	3.8	3.7	3.6	3.5	
	PLVL8H3-35075 315 x 63mm	5.0	4.7	4.5	4.4	4.2	4.1	4.0	3.9	3.8	3.8	
	PLVL8H3-40075 360 x 63mm	5.5	5.2	5.0	4.8	4.7	4.5	4.4	4.3	4.2	4.2	
	PLVL8H3-150100 140 x 88mm	2.9	2.8	2.7	2.6	2.5	2.4	2.3	2.3	2.2	2.2	
	PLVL8H3-200100 190 x 88mm	3.7	3.5	3.4	3.2	3.1	3.0	3.0	2.9	2.8	2.8	
	PLVL8H3-250100 240 x 88mm	4.4	4.2	4.0	3.9	3.7	3.6	3.5	3.5	3.4	3.3	
	PLVL8H3-300100 290 x 88mm	5.1	4.8	4.6	4.5	4.3	4.2	4.1	4.0	3.9	3.8	
With Ceiling	PLVL8H3-350100 315 x 88mm	5.4	5.1	4.9	4.8	4.6	4.5	4.4	4.3	4.2	4.1	
	PLVL8H3-400100 360 x 88mm	6.0	5.7	5.5	5.3	5.1	5.0	4.8	4.7	4.6	4.5	
	PLVL8H3-15075 140 x 63mm	2.5	2.4	2.2	2.1	2.1	2.0	1.9	1.9	1.8	1.8	
	PLVL8H3-20075 190 x 63mm	3.4	3.2	3.0	2.9	2.8	2.7	2.6	2.5	2.5	2.4	
	PLVL8H3-25075 240 x 63mm	4.0	3.8	3.7	3.6	3.4	3.3	3.3	3.2	3.1	3.0	
	PLVL8H3-30075 290 x 63mm	4.7	4.4	4.3	4.1	4.0	3.9	3.8	3.7	3.6	3.5	
	PLVL8H3-35075 315 x 63mm	5.0	4.7	4.5	4.4	4.2	4.1	4.0	3.9	3.8	3.8	
	PLVL8H3-40075 360 x 63mm	5.5	5.2	5.0	4.8	4.7	4.6	4.4	4.3	4.2	4.2	
	PLVL8H3-150100 140 x 88mm	2.8	2.6	2.5	2.4	2.3	2.2	2.1	2.1	2.0	2.0	
	PLVL8H3-200100 190 x 88mm	3.7	3.5	3.3	3.2	3.1	3.0	2.9	2.8	2.7	2.7	
With Ceiling	PLVL8H3-250100 240 x 88mm	4.4	4.2	4.0	3.9	3.7	3.6	3.5	3.5	3.4	3.3	
	PLVL8H3-300100 290 x 88mm	5.1	4.8	4.6	4.5	4.3	4.2	4.1	4.0	3.9	3.8	
	PLVL8H3-350100 315 x 88mm	5.4	5.1	4.9	4.7	4.6	4.5	4.4	4.3	4.2	4.1	
	PLVL8H3-400100 360 x 88mm	6.0	5.7	5.4	5.3	5.1	4.9	4.8	4.7	4.6	4.5	

Note The design parameters are specified in the design data page. For different parameters, refer to Prolam Online Specifier at [specifier.prolamnz.com](http://specifier.prolamnz.com)

This table applies only to Prolam products.

Span Tables

Table 7

Prolam® Floor Beam supporting joists

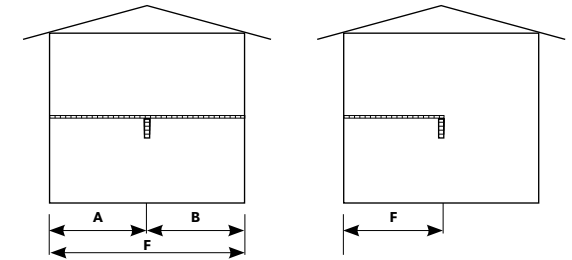

		Joist Span (m) 'F'						
		2.4	3.0	3.6	4.8	6.0	7.2	8.4
Beam Size		Maximum Beam Span (m)						
PL8	PL8H1-150100 140 x 90mm	2.2	2.2	2.1	1.8	1.6	1.4	1.3
	PL8H1-200100 190 x 90mm	3.0	3.0	2.8	2.4	2.2	2.0	1.8
	PL8H1-250100 240 x 90mm	3.8	3.8	3.6	3.1	2.8	2.5	2.3
	PL8H1-300100 290 x 90mm	4.6	4.6	4.3	3.8	3.4	3.1	2.8
	PL8H1-350100 315 x 90mm	5.0	5.0	4.7	4.1	3.7	3.3	3.0
PL12	PL12H1-150100 140 x 90mm	2.5	2.5	2.4	2.1	1.8	1.7	1.5
	PL12H1-200100 190 x 90mm	3.4	3.4	3.3	2.8	2.5	2.3	2.1
	PL12H1-250100 240 x 90mm	4.3	4.3	4.1	3.6	3.2	2.9	2.6
	PL12H1-300100 290 x 90mm	5.2	5.2	5.0	4.3	3.9	3.5	3.2
	PL12H1-350100 315 x 90mm	5.6	5.6	5.4	4.7	4.2	3.8	3.5

Note For 1.5 kPa L.L. refer to Prolam Online at [specifier.prolamnz.com](http://specifier.prolamnz.com)

Note The design parameters are specified in the design data page. For different parameters, refer to Prolam Online Specifier at [specifier.prolamnz.com](http://specifier.prolamnz.com)

This table applies only to Prolam products.

## Span Tables

**Table 8a**

**Prolam® Floor Joist PL8**

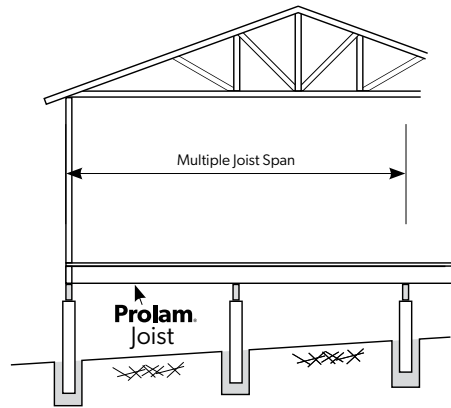

Notes:

1. Timber grade PL8 – dry use.
2. Joists do not support roof loads.
3. Spans may be increased by 10% for joists continuous over 2 or more equal spans.
4. Blocking required in accordance with NZS3604:2011 Clause 7.1.2.

Joist Spacing (m)		400	450	600	
Joist Size (m)		Floor Joists Single Span (m)			
PL8	PL8H3-15050	140 x 42mm	1.6	1.6	1.6
	PL8H3-20050	190 x 42mm	2.6	2.6	2.6
	PL8H3-25050	240 x 42mm	3.7	3.7	3.6
	PL8H3-30050	290 x 42mm	4.5	4.5	4.4
	PL8H3-35050	315 x 42mm	4.9	4.9	4.8
	PL8H3-40050	360 x 42mm	5.6	5.6	5.4
	PL8H3-45050	405 x 42mm	6.3	6.3	5.9
	PL8H3-15075	140 x 63mm	2.0	2.0	2.0
	PL8H3-20075	190 x 63mm	3.3	3.3	3.3
	PL8H3-25075	240 x 63mm	4.2	4.2	4.2
	PL8H3-30075	290 x 63mm	5.1	5.1	5.1
	PL8H3-35075	315 x 63mm	5.6	5.6	5.4
	PL8H3-40075	360 x 63mm	6.4	6.4	6.0
	PL8H3-45075	405 x 63mm	7.2	7.0	6.5

**Note** The design parameters are specified in the design data page. For different parameters, refer to Prolam Online Specifier at [specifier.prolamnz.com](http://specifier.prolamnz.com)

**These span tables apply only to Prolam products.**

## Span Tables

**Table 8b**

**Prolam® Floor Joist PL12**

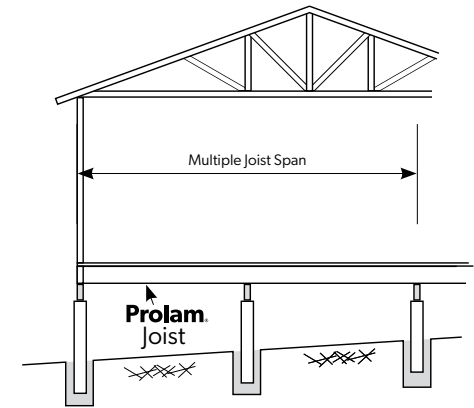

Notes:

1. Timber grade PL12 – dry use.
2. Joists do not support roof loads.
3. Spans may be increased by 10% for joists continuous over 2 or more equal spans.
4. Blocking required in accordance with NZS3604:2011 Clause 7.1.2.

Joist Spacing (m)		400	450	600	
Joist Size (m)		Floor Joists Single Span (m)			
PL12	PL12H3-15050	140 x 42mm	2.0	2.0	2.0
	PL12H3-20050	190 x 42mm	3.2	3.2	3.2
	PL12H3-25050	240 x 42mm	4.2	4.2	4.1
	PL12H3-30050	290 x 42mm	5.1	5.1	5.0
	PL12H3-35050	315 x 42mm	5.5	5.5	5.3
	PL12H3-40050	360 x 42mm	6.3	6.3	5.9
	PL12H3-45050	405 x 42mm	7.1	7.0	6.5
	PL12H3-15075	140 x 63mm	2.4	2.4	2.4
	PL12H3-20075	190 x 63mm	3.8	3.8	3.7
	PL12H3-25075	240 x 63mm	4.8	4.8	4.7
	PL12H3-30075	290 x 63mm	5.8	5.8	5.6
	PL12H3-45075	315 x 63mm	6.3	6.3	5.9
	PL12H3-40075	360 x 63mm	7.2	7.1	6.6
	PL12H3-45075	405 x 63mm	8.0	7.7	7.2

**Note** The design parameters are specified in the design data page. For different parameters, refer to Prolam Online Specifier at [specifier.prolamnz.com](http://specifier.prolamnz.com)

**These span tables apply only to Prolam products.**

### Span Tables

**Table 9**

**Prolam® Deck Bearer** supporting deck and cantilever

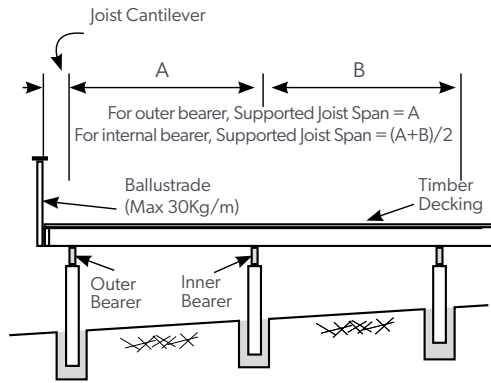

Notes:

1. Minimum H3.2 treated – wet use.
2. Bearers do not support roof loads.
3. Maximum ballustrade weight 30kg/m.
4. Maximum joist cantilever 400mm.
5. Spans may be increased by 10% for bearers continuous over 2 or more spans.

Joist Span (m)		0.9	1.2	1.5	1.8	2.4	3.0	3.6	4.2	4.8	
Bearer Size (m)		Maximum Bearer Span (m)									
PL8	PL8H3-150100 140 x 90mm	1.9	1.8	1.8	1.6	1.4	1.2	1.1	1.0	1.0	
	PL8H3-200100 190 x 90mm	2.6	2.5	2.4	2.2	1.9	1.7	1.6	1.4	1.3	
	PL8H3-250100 240 x 90mm	3.3	3.2	3.1	2.8	2.4	2.2	2.0	1.8	1.7	
	PL8H3-300100 290 x 90mm	4.0	3.9	3.7	3.4	3.0	2.6	2.4	2.2	2.1	
	PL8H3-350100 315 x 90mm	4.3	4.2	4.1	3.7	3.2	2.9	2.6	2.4	2.3	
	PL8H3-400100 360 x 90mm	4.9	4.8	4.6	4.3	3.7	3.3	3.0	2.8	2.6	
PL12	PL12H3-150100 140 x 90mm	2.2	2.1	2.0	1.9	1.6	1.4	1.3	1.2	1.1	
	PL12H3-200100 190 x 90mm	3.0	2.9	2.8	2.6	2.2	2.0	1.8	1.7	1.5	
	PL12H3-250100 240 x 90mm	3.7	3.6	3.5	3.3	2.8	2.5	2.3	2.1	2.0	
	PL12H3-300100 290 x 90mm	4.5	4.4	4.2	3.9	3.4	3.0	2.8	2.6	2.4	
	PL12H3-350100 315 x 90mm	4.9	4.7	4.6	4.3	3.7	3.3	3.0	2.8	2.6	
	PL12H3-400100 360 x 90mm	5.6	5.4	5.2	4.9	4.2	3.8	3.5	3.2	3.0	

**Note** The design parameters are specified in the design data page. For different parameters, refer to Prolam Online Specifier at [specifier.prolamnz.com](http://specifier.prolamnz.com)

**These span tables apply only to Prolam products.**

### Span Tables

**Table 10**

**Prolam® Deck Joist**

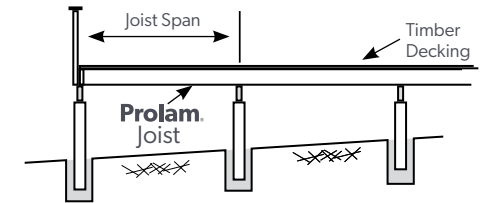

Notes:

1. Minimum H3.2 treated – wet use.
2. No ceiling or soft lining.
3. Joists do not support roof loads.
4. Spans may be increased by 10% for joists continuous over 2 or more spans.
5. Blocking required in accordance with NZS3604:2011 Clause 7.1.2.

Joist Spacing (m)		0.40	0.45	0.60
Joist Size (m)		Deck Joists Single Span (m)		
PL8	PL8H3-15050 140 x 42mm	1.5	1.5	1.5
	PL8H3-20050 190 x 42mm	2.4	2.4	2.4
	PL8H3-25050 240 x 42mm	3.4	3.4	3.2
	PL8H3-30050 290 x 42mm	4.2	4.2	3.8
	PL8H3-35050 315 x 42mm	4.5	4.5	4.2
	PL8H3-40050 360 x 42mm	5.2	5.2	4.8
	PL8H3-45050 405 x 42mm	5.8	5.7	5.3
	PL8H3-15075 140 x 63mm	1.8	1.8	1.8
	PL8H3-20075 190 x 63mm	2.9	2.9	2.9
	PL8H3-25075 240 x 63mm	3.9	3.9	3.6
PL8H3-30075 290 x 63mm	4.8	4.8	4.4	
PL8H3-35075 315 x 63mm	5.2	5.2	4.8	
PL8H3-40075 360 x 63mm	5.9	5.8	5.4	
PL8H3-45075 405 x 63mm	6.5	6.3	5.9	

**Note** The design parameters are specified in the design data page. For different parameters, refer to Prolam Online Specifier at [specifier.prolamnz.com](http://specifier.prolamnz.com)

**These span tables apply only to Prolam products.**

## Span Tables

**Table 11**  
**Prolam® Deck Post Bracing Units**

1. Piles supporting timber deck constructed to NZS 3604:2011 Clause 7.4.
2. Post to bearer fixing is for lateral loads. Vertical (bearing) loads may require additional capacity
3. Footing depth is into Good Ground as defined by NZS3604

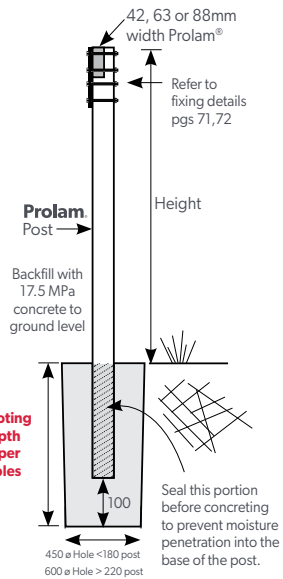

**Note** The design parameters are specified in the design data page. For different parameters, refer to Prolam Online Specifier at [specifier.prolamnz.com](http://specifier.prolamnz.com)

**These span tables apply only to Prolam products.**

Prolam Post Deck Pile	Height (m)	BU Rating	Footing Depth (m)	Footing Diameter (mm)	Post to bearer Fixing
PLPH5-150 135x135	0.75	20	1.0	450	6kN
	1.00	17	1.0	450	6kN
	1.20	15	1.0	450	6kN
	1.50	13	1.0	450	6kN
	1.80	12	1.0	450	6kN
PLPH5-200 180x180	1.00	40	1.2	450	6kN
	1.20	36	1.2	450	6kN
	1.50	31	1.2	450	6kN
	1.80	28	1.2	450	6kN
	2.10	25	1.2	450	6kN
	2.40	21	1.2	450	6kN
	2.70	15	1.2	450	6kN
	3.00	11	1.2	450	6kN
PLPH5-250 220x220	1.60	50	1.5	600	12kN
	1.80	47	1.5	600	12kN
	2.10	42	1.5	600	12kN
	2.40	39	1.5	600	12kN
	2.70	34	1.5	600	12kN
	3.00	25	1.5	600	12kN
	3.30	19	1.5	600	12kN
	3.60	15	1.5	600	12kN
PLPH5-300 260x260	2.20	67	1.7	600	12kN
	2.40	63	1.7	600	12kN
	2.70	58	1.7	600	12kN
	3.00	49	1.7	600	12kN
	3.30	37	1.7	600	12kN
	3.60	29	1.7	600	12kN
	3.90	23	1.7	600	12kN
	4.20	18	1.7	600	12kN
PLP12H5-150 135x135	0.75	26	1.1	450	6kN
	1.00	22	1.1	450	6kN
	1.20	20	1.1	450	6kN
	1.50	18	1.1	450	6kN
	1.80	15	1.1	450	6kN
	2.10	13	1.1	450	6kN
PLP12H5-200 180x180	1.00	53	1.3	450	6kN
	1.20	47	1.3	450	6kN
	1.50	41	1.3	450	6kN
	1.80	37	1.3	450	6kN
	2.10	33	1.3	450	6kN
	2.40	30	1.3	450	6kN
	2.70	22	1.3	450	6kN
	3.00	16	1.3	450	6kN
PLP12H5-250 220x220	1.80	61	1.6	600	12kN
	2.10	55	1.6	600	12kN
	2.40	51	1.6	600	12kN
	2.70	47	1.6	600	12kN
	3.00	36	1.6	600	12kN
	3.30	27	1.6	600	12kN
	3.60	21	1.6	600	12kN
	4.20	18	1.6	600	12kN
PLP12H5-300 260x260	2.20	88	1.8	600	12kN
	2.40	83	1.8	600	12kN
	2.70	77	1.8	600	12kN
	3.00	71	1.8	600	12kN
	3.30	53	1.8	600	12kN
	3.60	41	1.8	600	12kN
	3.90	33	1.8	600	12kN
	4.20	26	1.8	600	12kN

## Prolam® Veranda/Carport Bracing Post

1. Earthquake zone 3 - Soil Class E
2. Post to bearer fixing is for lateral loads. Vertical bearing loads may require additional capacity.
3. Footing depth is into Good Ground. Footing is sized for resisting bracing loads only.
4. Requirements for resisting uplift will need to be calculated separately - Section 9 in NZS3604:2011 gives tables for the uplift force and volume of concrete required for posts.

### Post selection steps:

1. Calculate total plan and face areas of the Veranda roof:  
Total Plan area:  $TPA = W \times L$   
Total Face area:  $TFA = H \times L$
2. Select the post size desired and the post height
3. Read off the maximum areas AP and AF for that post
4. Number of posts required will equal the maximum of:  $TPA/AP$  or  $TFA/AF$
5. If the number of posts is more than desired then select a larger post size and repeat the calculations.

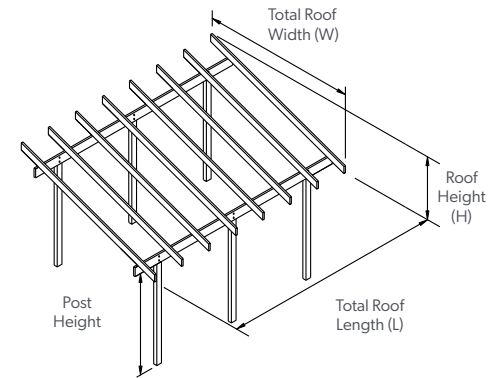

### Example (PL8 Bracing Post Supporting Free Standing Veranda/Carport - Table 12a):

Roof Length = 6      Roof Width = 4      Roof Height = 1.2

$$TPA = 24$$

$$TFA = 7.2$$

Post size = 180x180      Post height = 2.1

$$AP = 6.3$$

$$AF = 2.6$$

$$TPA/AP = 3.8$$

$$TFA/AF = 2.8$$

Number of posts required = 4 (3.8 rounded up)

**These span tables apply only to Prolam products.**

Span Tables

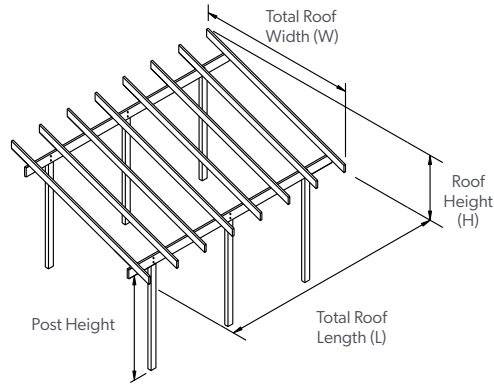

Table 12a

Prolam® Bracing Post Veranda/Carport - free standing supporting roof and ceiling PL8

Post Size	Post Height (m)	Maximum plan area per post (AP) (m <sup>2</sup> )	Maximum face area per post (AF) (m <sup>2</sup> )	Footing Depth (m)	Footing Diameter (mm)	Post to Bearer Fixing (kN)
PLPH5-150 135x135mm	1.80	3.0	1.1	1.0	450	6
	2.10	2.7	0.8	1.0	450	6
	2.40	2.4	0.6	1.0	450	6
PLPH5-200 180x180mm	1.80	7.0	3.4	1.2	450	12
	2.10	6.3	2.6	1.2	450	6
	2.40	5.7	2.0	1.2	450	6
	2.70	5.2	1.6	1.2	450	6
	3.00	4.8	1.2	1.2	450	6
	3.30	4.3	0.9	1.2	450	6
PLPH5-250 220x220mm	1.80	11.7	5.9	1.5	600	12
	2.10	10.6	5.4	1.5	600	12
	2.40	9.7	4.4	1.5	600	12
	2.70	8.9	3.5	1.5	600	12
	3.00	8.2	2.8	1.5	600	12
	3.30	7.7	2.1	1.5	600	12
	3.60	7.2	1.6	1.5	600	12
PLPH5-300 260x260mm	2.20	16.9	8.6	1.7	600	12
	2.40	16.0	8.1	1.7	600	12
	2.70	14.7	6.9	1.7	600	12
	3.00	13.6	5.4	1.7	600	12
	3.30	12.6	4.1	1.7	600	12
	3.60	11.8	3.2	1.7	600	12
	3.90	11.1	2.5	1.7	600	12
	4.20	9.3	2.0	1.7	600	12

Note: The design parameters are specified in the design data page. For different parameters, refer to Prolam Online Specifier at specifier.prolamnz.com

These span tables apply only to Prolam products.

Span Tables

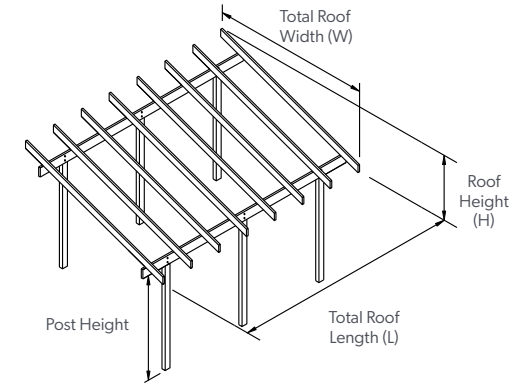

Table 12b

Prolam® Bracing Post Veranda/Carport - free standing supporting roof and ceiling PL12

Post Size	Post Height (m)	Maximum plan area per post (AP) (m <sup>2</sup> )	Maximum face area per post (AF) (m <sup>2</sup> )	Footing Depth (m)	Footing Diameter (mm)	Post to Bearer Fixing (kN)
PLP12H5-150 135x135mm	1.80	3.9	1.6	1.1	450	6
	2.10	3.5	1.2	1.1	450	6
	2.40	3.2	0.9	1.1	450	6
PLP12H5-200 180x180mm	1.80	9.2	4.7	1.3	450	12
	2.10	8.2	3.7	1.3	450	12
	2.40	7.5	2.9	1.3	450	6
	2.70	6.8	2.3	1.3	450	6
	3.00	6.3	1.8	1.3	450	6
	3.30	5.8	1.4	1.3	450	6
PLP12H5-250 220x220mm	1.80	15.4	7.8	1.6	600	12
	2.10	14.0	7.1	1.6	600	12
	2.40	12.7	6.4	1.6	600	12
	2.70	11.7	5.1	1.6	600	12
	3.00	10.8	4.0	1.6	600	12
	3.30	10.1	3.0	1.6	600	12
	3.60	9.4	2.4	1.6	600	12
PLP12H5-300 260x260mm	2.20	22.3	11.3	1.8	600	12
	2.40	21.0	10.6	1.8	600	12
	2.70	19.3	9.8	1.8	600	12
	3.00	17.9	7.8	1.8	600	12
	3.30	16.6	5.9	1.8	600	12
	3.60	15.5	4.6	1.8	600	12
	3.90	14.6	3.6	1.8	600	12
	4.20	13.3	2.9	1.8	600	12

Note: The design parameters are specified in the design data page. For different parameters, refer to Prolam Online Specifier at specifier.prolamnz.com

These span tables apply only to Prolam products.

Span Tables

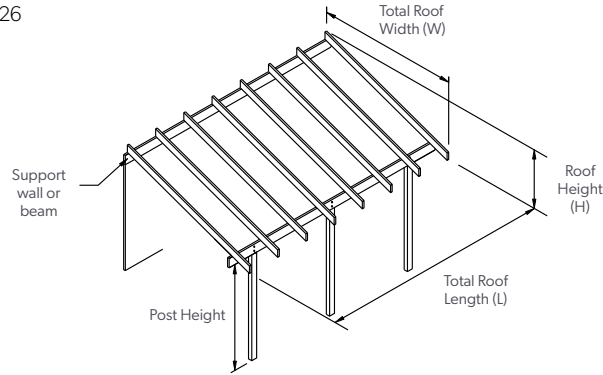

Table 12c

Prolam® Bracing Post Veranda/Carport - attached to house supporting roof and ceiling - PL8

Post Size	Post Height (m)	Maximum plan area per post (AP) (m²)	Maximum face area per post (AF) (m²)	Footing Depth (m)	Footing Diameter (mm)	Post to Bearer Fixing (kN)
PLPH5-150 135x135mm	1.80	5.9	2.2	1.0	450	6
	2.10	5.3	1.6	1.0	450	6
	2.40	4.8	1.3	1.0	450	6
PLPH5-200 180x180mm	1.80	14.0	6.9	1.2	450	12
	2.10	12.5	5.1	1.2	450	6
	2.40	11.4	4.0	1.2	450	6
	2.70	10.4	3.2	1.2	450	6
	3.00	9.6	2.5	1.2	450	6
	3.30	8.6	1.9	1.2	450	6
PLPH5-250 220x220mm	1.80	23.5	11.9	1.5	600	12
	2.10	21.2	10.7	1.5	600	12
	2.40	19.4	8.9	1.5	600	12
	2.70	17.8	7.1	1.5	600	12
	3.00	16.5	5.6	1.5	600	12
	3.30	15.3	4.2	1.5	600	12
PLPH5-300 260x260mm	3.60	14.3	3.3	1.5	600	12
	2.20	33.9	17.1	1.7	600	12
	2.40	31.9	16.1	1.7	600	12
	2.70	29.4	13.8	1.7	600	12
	3.00	27.2	10.9	1.7	600	12
	3.30	25.3	8.2	1.7	600	12
	3.60	23.6	6.4	1.7	600	12
	3.90	22.2	5.1	1.7	600	12
4.20	18.5	4.1	1.7	600	12	

Note: The design parameters are specified in the design data page. For different parameters, refer to Prolam Online Specifier at specifier.prolamnz.com

These span tables apply only to Prolam products.

Span Tables

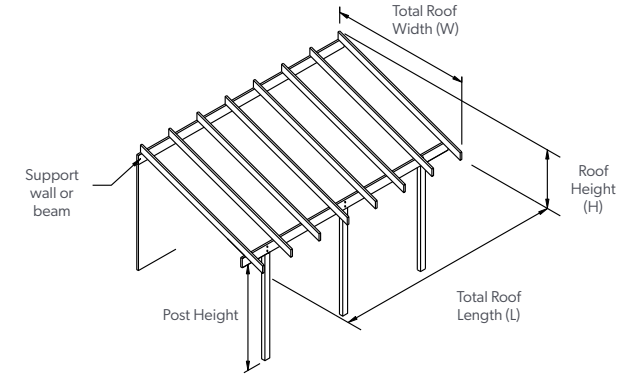

Table 12d

Prolam® Bracing Post Veranda/Carport - attached to house supporting roof and ceiling - PL12

Post Size	Post Height (m)	Maximum plan area per post (AP) (m²)	Maximum face area per post (AF) (m²)	Footing Depth (m)	Footing Diameter (mm)	Post to Bearer Fixing (kN)
PLP12H5-150 135x135mm	1.80	7.8	3.1	1.1	450	6
	2.10	7.0	2.3	1.1	450	6
	2.40	6.3	1.8	1.1	450	6
PLP12H5-200 180x180mm	1.80	18.4	9.3	1.3	450	12
	2.10	16.5	7.4	1.3	450	12
	2.40	14.9	5.7	1.3	450	6
	2.70	13.7	4.5	1.3	450	6
	3.00	12.6	3.6	1.3	450	6
	3.30	11.7	2.7	1.3	450	6
PLP12H5-250 220x220mm	1.80	30.9	15.6	1.6	600	12
	2.10	27.9	14.1	1.6	600	12
	2.40	25.5	12.7	1.6	600	12
	2.70	23.4	10.1	1.6	600	12
	3.00	21.7	8.0	1.6	600	12
	3.30	20.2	6.1	1.6	600	12
PLP12H5-300 260x260mm	3.60	18.9	4.7	1.6	600	12
	2.20	44.5	22.5	1.8	600	12
	2.40	41.9	21.2	1.8	600	12
	2.70	38.6	19.5	1.8	600	12
	3.00	35.7	15.6	1.8	600	12
	3.30	33.2	11.8	1.8	600	12
	3.60	31.1	9.2	1.8	600	12
	3.90	29.2	7.3	1.8	600	12
4.20	26.6	5.9	1.8	600	12	

Note: The design parameters are specified in the design data page. For different parameters, refer to Prolam Online Specifier at specifier.prolamnz.com

These span tables apply only to Prolam products.

## Span Tables

**Table 13**

**Prolam® Non-Bracing Post** - attached to house supporting veranda roof and ceiling only

1. Post height is measured from ground level to top of roof beam.
2. Veranda or carport 2.0m or less and attached to the house, does not require bracing.
3. Refer to NZS3604:2011 section 9 for size of concrete footing to resist uplift.
4. For post sizes to roof that require bracing refer to separate tables.

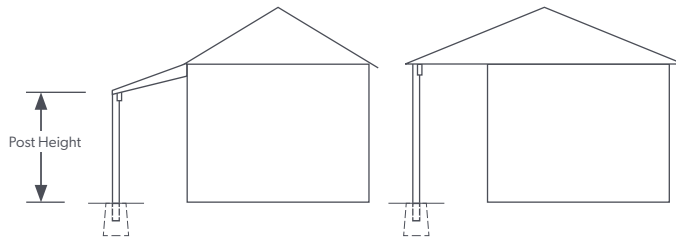

Veranda Post	Maximum Post Height from Ground (m)	Maximum Supported Roof Area per Post (m <sup>2</sup> )
PLPH5-100 88 x 88mm	2.4	16
PLPH5-125 112 x 112mm	3	27
PLPH5-150 135 x 135mm	3.6	39
PLPH5-200 180 x 180mm	4.2	50

$$\text{Roof Area} = \text{Roof Width} \times \text{Post Spacing} / 2$$

Note: The design parameters are specified in the design data page. For different parameters, refer to Prolam Online Specifier at [specifier.prolamnz.com](http://specifier.prolamnz.com)

**These span tables apply only to Prolam products.**

## Span Tables

**Table 14**

**Prolam® Non-Bracing Post** - attached to house supporting veranda or deck floor only

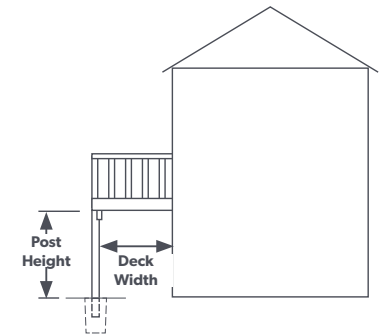

Post Height From Ground (m)	1.8	2.4	2.7	3.0	3.6	4.2
<b>Deck Post</b>	<b>Maximum Supported Deck Area per Post (m<sup>2</sup>)</b>					
PLPH5-125 112 x 112mm	8	7.3	6.9	6.4	-	-
PLPH5-150 135 x 135mm	11.9	11.4	11	10.5	9.4	-
PLPH5-200 180 x 180mm	21.5	21.2	21	20.6	19.6	18.3
PLPH5-250 220x220mm	32.1	32.1	31.9	31.7	30.9	29.8
PLPH5-300 260x260mm	44.9	44.9	44.8	44.7	44.2	43.3

$$\text{Deck Area} = \frac{\text{Deck Width}}{2} \times \text{Post Spacing}$$

Note: The design parameters are specified in the design data page. For different parameters, refer to Prolam Online Specifier at [specifier.prolamnz.com](http://specifier.prolamnz.com)

**These span tables apply only to Prolam products.**

## Span Tables

**Table 15**

**Prolam® Non-bracing Post** - attached to house supporting veranda deck floor and roof with ceiling

1. Tributary roof area must be equal to the tributary floor area.
2. Post height is measured from ground level to floor bearer connection point.

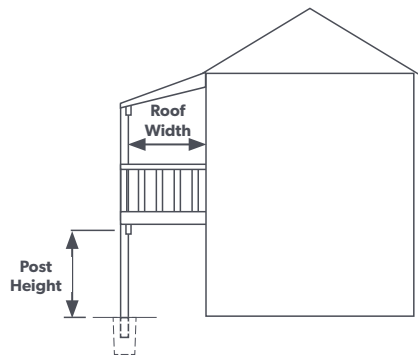

Veranda Post	Post Height From Ground (m)	Maximum Supported Roof Area per Post (m <sup>2</sup> )
<b>PLPH5-125</b> 112 x 112mm	3.0	5.0
<b>PLPH5-150</b> 135 x 135mm	3.6	8.0
<b>PLPH5-200</b> 180 x 180mm	4.2	16.0
<b>PLPH5-250</b> 220 x 220mm	4.2	26.0
<b>PLPH5-300</b> 260 x 260mm	4.2	38.0

Roof Area = Roof Width x Post Spacing / 2

Note: The design parameters are specified in the design data page. For different parameters, refer to Prolam Online Specifier at [specifier.prolamnz.com](https://specifier.prolamnz.com)

**These span tables apply only to Prolam products.**

# Fixings

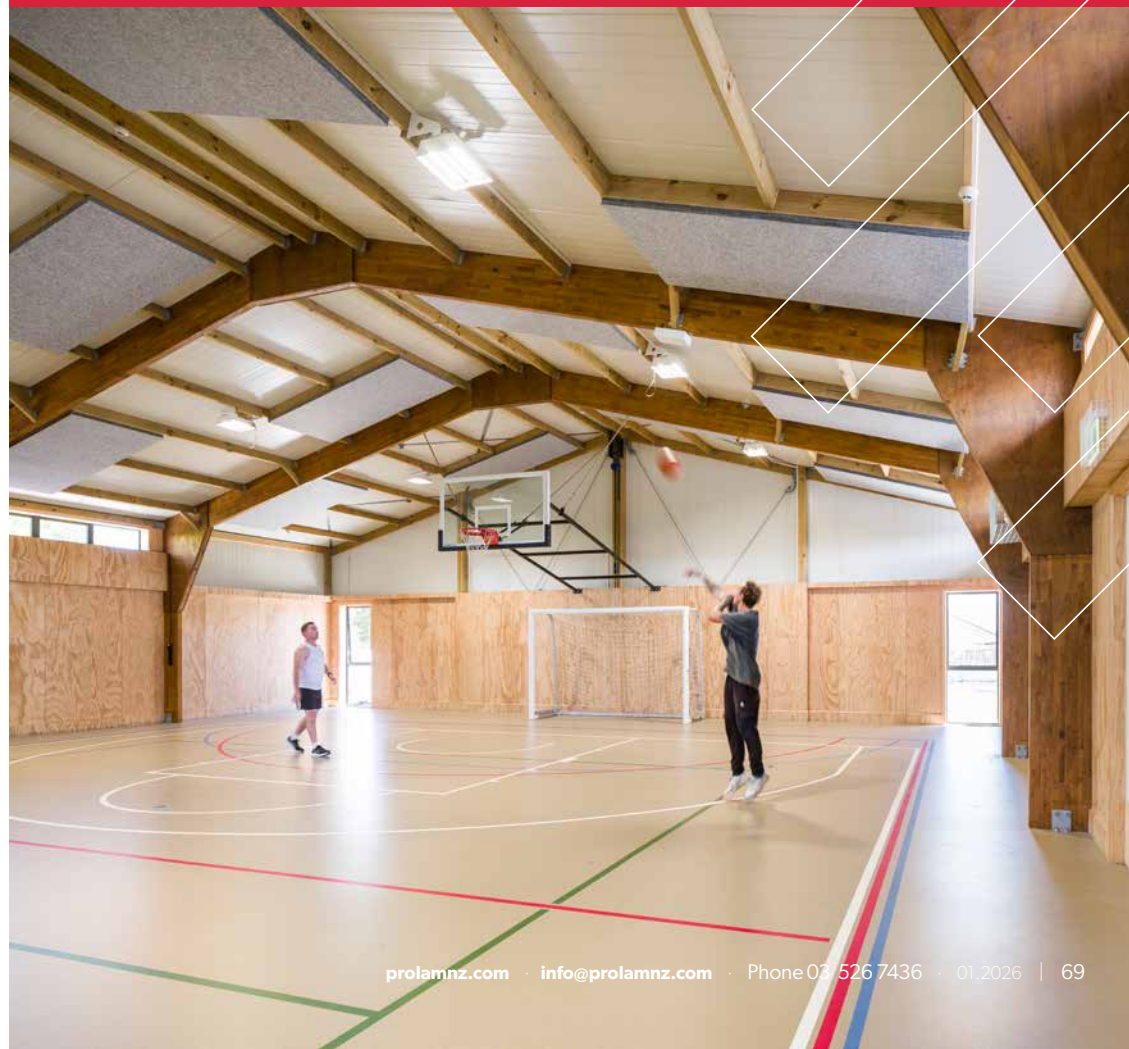

## Fixing to MCA Timber

Indirectly endorsed by BRANZ, Prolam recommends as a minimum, the specification and use of 304 stainless fasteners, nails and screws for any H3.2-H5 treated timber in all exterior and or exposed applications.

As stated in NZ3604 (4.4.4) Steel fixings and fastenings in contact with timber treated with copper based timber preservatives (H3.2 or higher) shall be as per table 4.1 and table 4.3 but shall also be a minimum of:

- a. Type 304 stainless steel for fixings in contact with timber treated with Copper Azole, or Alkaline Copper Quaternary (ACQ) preservatives, where used in exposed or sheltered locations.
- b. Hot-dipped galvanized for all other locations

If you specifically require a reduced durability period for bolted connections in non-structural situations such as fences and pergolas, we would still recommend referring to NZS3604 as a guide or consult with a building professional.



## Prolam® Tapered Ceiling Beam Detail

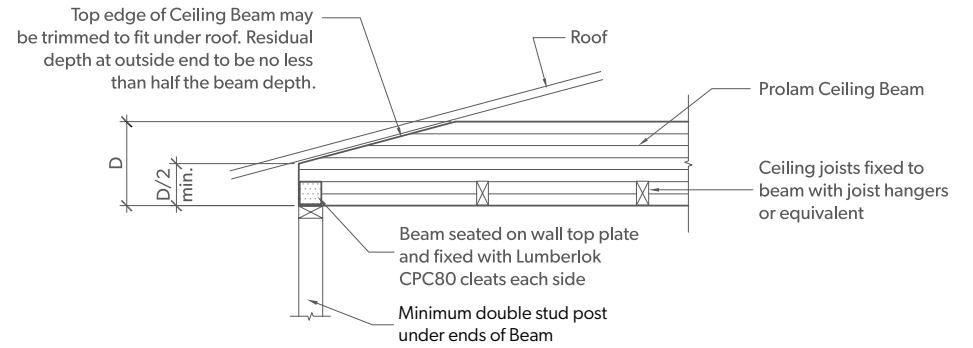

**ELEVATION AT END OF CEILING BEAM**

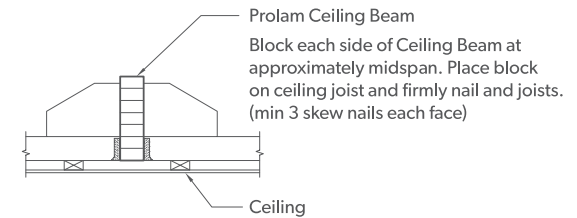

**SECTION THROUGH CEILING BEAM**

**This table applies only to Prolam products.**

# Prolam® Support for Bricks

Wall Height	Angle Size	Bolt Spacing
600mm	100 x 75 x 6mm	900mm
1200mm	100 x 75 x 6mm	900mm
1800mm	100 x 75 x 6mm	600mm
2100mm	100 x 75 x 8mm	500mm
2400mm	100 x 75 x 8mm	450mm
2700mm	100 x 75 x 8mm	400mm

Applies to bricks up to 90mm thickness.

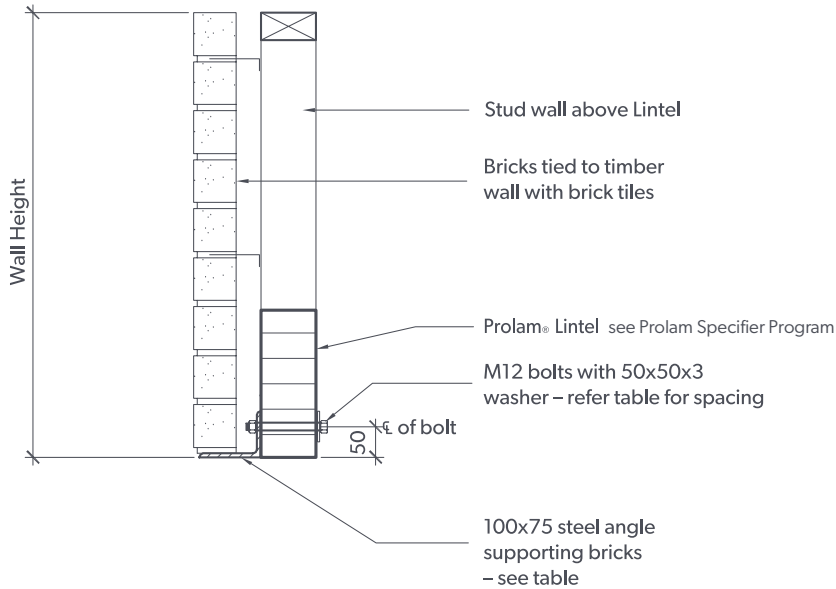

Refer to span tables on software program for lintel sizes.

**This table applies only to Prolam products.**

# Prolam® Post Fixings

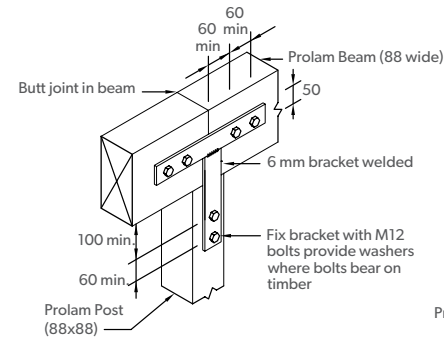

NOTE -  
 (1) Capacity 12.2 kN for 1 bracket.  
 (2) Capacity 25.5 kN for 2 brackets.

(A)

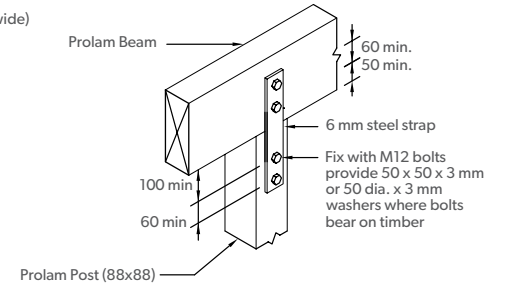

NOTE -  
 (1) Capacity 6.8 kN for 1 bracket.  
 (2) Capacity 13.7 kN for 2 brackets.

(B)

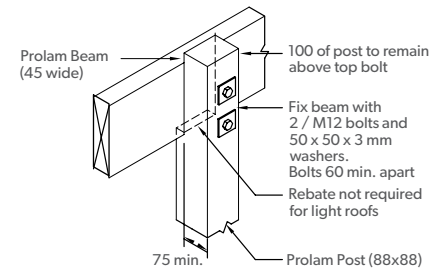

NOTE -  
 Capacity 6.8 kN.

(C)

Unless otherwise stated, all dimensions are in mm.

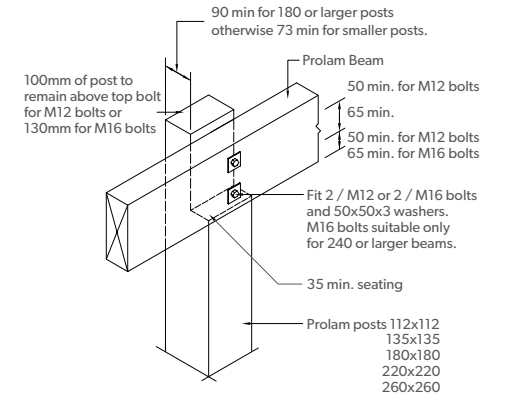

BEAM FIXING

(D)

Uplift capacity  
 2 / M12 bolts – 7.8 kN  
 2 / M16 bolts – 12.0 kN

# Prolam® Post Fixings

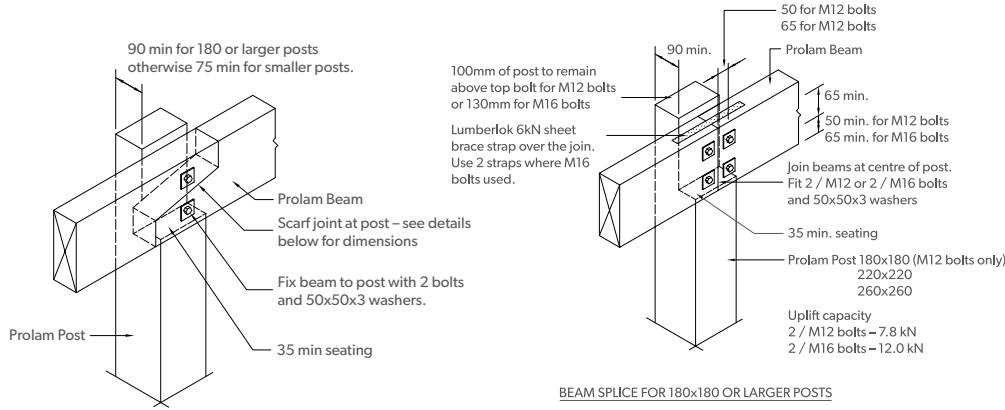

BEAM SPLICE FOR 180x180 OR LARGER POSTS

SCARF JOINT AT POSTS

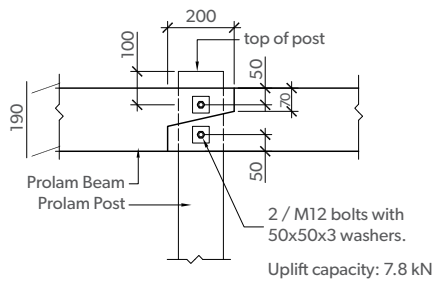

SCARF JOINT FOR 190 BEAMS

Not suitable for M16 bolts

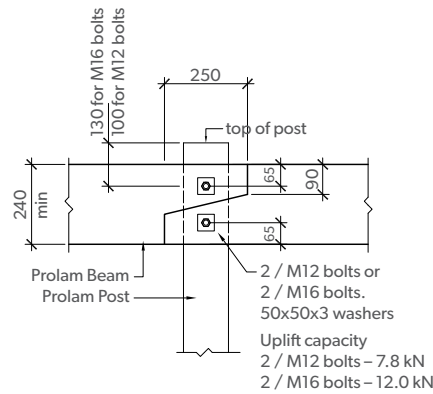

SCARF JOINT FOR 240 OR LARGER BEAMS

# Prolam® Corner Post Fixings

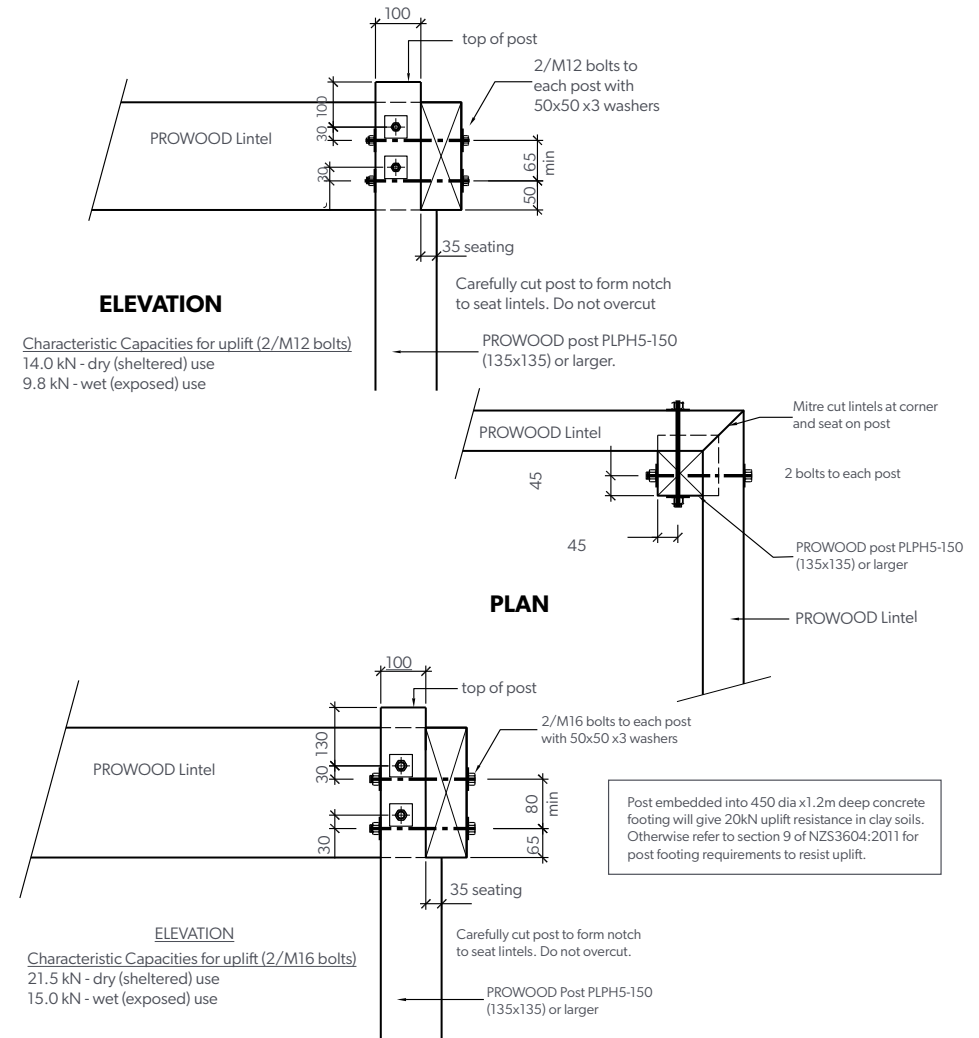

CORNER POST - LINTEL CONNECTION DETAIL

# Prolam PLX20® Fixings

## A1. RAFTER/TRUSS DIRECT CPC80 FIXING

- For use only with the MiTek 16KNTP Kit.
- Use 4 of the 8 provided Type 17-14g x 75 mm screws (2 each side) and discard the remainder.
- The choice of fixing holes to the rafters should be offset to avoid interfering with the opposite side fixings.

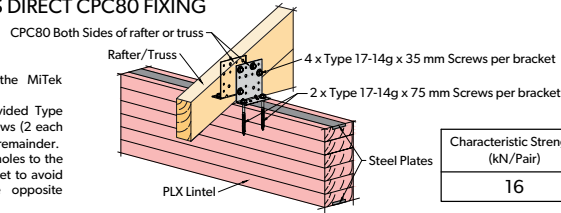

Characteristic Strength (kN/Pair)	ULS Capacity (kN/Pair)
16	11.2

## B1. RAFTER/TRUSS CPC80 FIXING WITH DOUBLE TOP PLATES

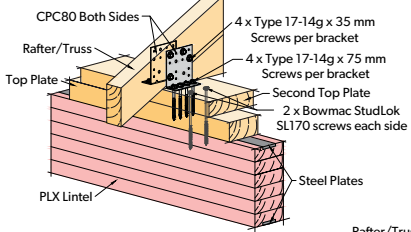

Characteristic Strength (kN/Pair)	ULS Capacity (kN/Pair)
16	11.2

## B2. RAFTER/TRUSS CPC80 FIXING WITH SINGLE TOP PLATE

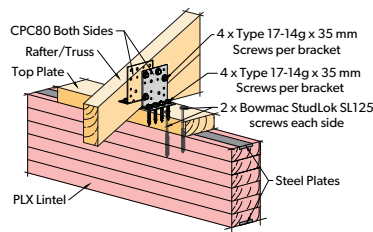

Characteristic Strength (kN/Pair)	ULS Capacity (kN/Pair)
16	11.2

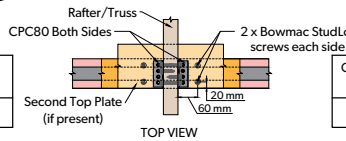

## C1. RAFTER/TRUSS CPC40 FIXING WITH DOUBLE TOP PLATES

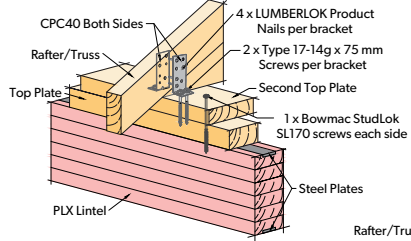

Characteristic Strength (kN/Pair)	ULS Capacity (kN/Pair)
8	5.6

## C2. RAFTER/TRUSS CPC40 FIXING WITH SINGLE TOP PLATE

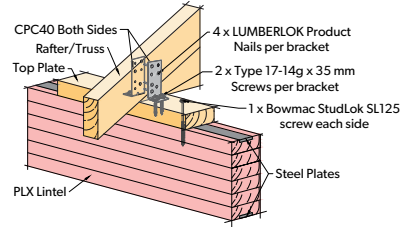

Characteristic Strength (kN/Pair)	ULS Capacity (kN/Pair)
8	5.6

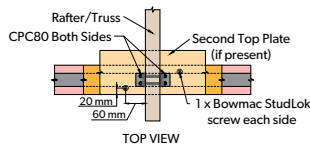

# Prolam PLX20® Fixings

## G1. RAFTER/TRUSS CYCLONE STRAP FACE FIXING

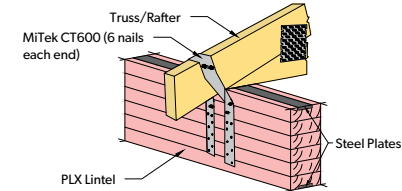

Characteristic Strength (kN)	ULS Capacity (kN)
12.0	9.6

## H1. RAFTER/TRUSS CEILING TIE FACE FIXING

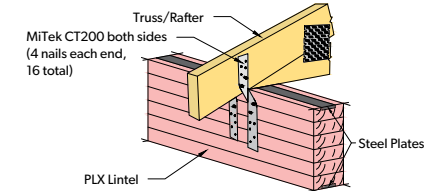

Characteristic Strength (kN/Pair)	ULS Capacity (kN/Pair)
10.5	8.4

## I1. RAFTER/TRUSS DIAGONAL CLEAT N21 FACE FIXING

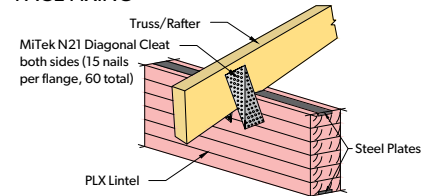

Characteristic Strength (kN/Pair)	ULS Capacity (kN/Pair)
20.0	16.0

## J1. RAFTER/TRUSS CEILING & PURLIN HANGER FACE FIXING

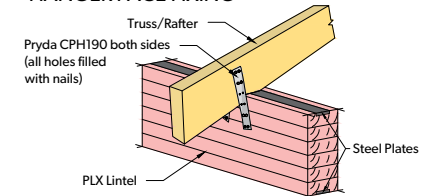

Characteristic Strength (kN/Pair)	ULS Capacity (kN/Pair)
-	5.0

## K1. RAFTER/TRUSS Z-NAIL FACE FIXING

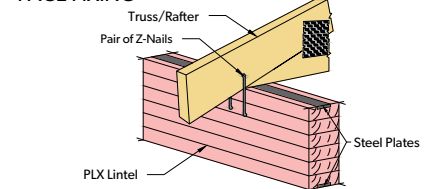

Characteristic Strength (kN/Pair)	ULS Capacity (kN/Pair)
3.2	2.5

## L1. RAFTER/TRUSS MULTIGRIP FACE FIXING

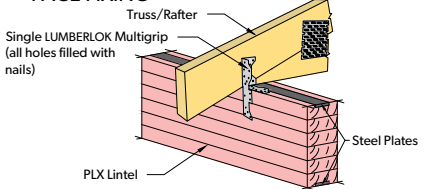

Characteristic Strength (kN/each)	ULS Capacity (kN/each)
4.0	3.2

# Prolam® Stud Requirement Table

## Construction Specifications

Walls are to be fully lined on at least one face. Full bearing on top plate (i.e. no eccentric loading).

Bearing Reaction	Stud Requirement for Concentrated Loads	
	Stud Height	Requirements
Bearing reaction up to & including 10kN	2400	Refer to NZS 3604:2011
	2700	
	3000	
	Stud Height	Stud Required
Bearing reaction up to & including 20kN	2400	PL8H5-100 90 x 90
	2700	PL8H5-100 90 x 90
	3000	PL8H1-150 140 x 90
	Stud Height	Stud Required
Bearing reaction up to & including 30kN	2400	PL8H1-150 140 x 90
	2700	PL8H1-150 140 x 90
	3000	PL8H1-200 190 x 90

\* Note The stud requirement for 20 kN & 30 kN bearing reactions can be applied to external walls as well. Reactions over 30kN will require specific design.

**These span tables apply only to Prolam products.**

# Prolam® Holes in Laminated Timber

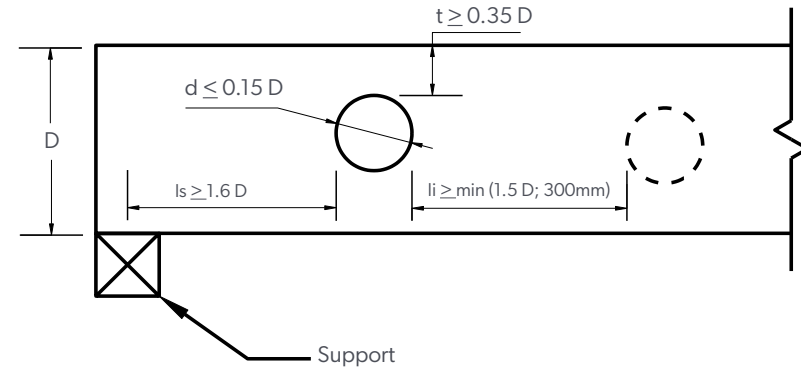

Beam Depth (d) (mm)	Max Hole Dia. (d) (mm)	Min. Edge Dist. (t) (mm)	Min. Edge Dist. (ls) (mm)
140	20	50	230
190	25	70	310
240	35	85	390
290	45	105	470
315	50	115	510
360	55	130	580
405	60	145	655
450	70	160	725
495	75	175	800
540	80	190	870
595	90	210	960

No holes in cantilever joist Circular Holes are only Permitted.

**This table applies only to Prolam products.**

## FAQs

### Why should I use Prolam Glulam instead of steel?

#### Here are just a few reasons:

- ▶ Easier and lighter to handle and fix
- ▶ Friendlier on the environment - stores carbon rather than emitting it
- ▶ Uses NZ's only renewable construction material - plantation timber
- ▶ Uses 14 times less energy to produce than equivalent steel beam
- ▶ Superior Fire Resistance compared to steel
- ▶ Lower maintenance - Glulam does not rust or corrode
- ▶ Cost effective - no boxing in or covering as with steel beams
- ▶ Appearance - natural warmth and beauty of timber cannot be reproduced in steel
- ▶ Will not buckle or distort in response to temperature changes
- ▶ Direct fixing of plates, joists and other connections is much easier

### Why should I use Prolam Glulam instead of solid timber?

Because Prolam Glulam is manufactured from selected grade, kiln-dried material it is more stable than a sawn timber beam of the same section. The tendency of large section sawn timber to twist, split and shrink is greatly minimised in Prolam. A Prolam beam can reduce the overall section of members up to 40% compared to unseasoned timber, as they are pretensioned.

### What type of quality assurance comes with Prolam Glulam Beams?

All Prolam Glulam is manufactured to comply with the Australia and New Zealand Standard AS/NZS1328 and AS5096 - Glue Laminated Structural Timber A.

### Can Prolam Glulam beams be used in exterior situations?

Yes. Prolam posts and beams treated to H3 or H5 may be used in exterior situations provided that they are finished with a paint or staincoating. Prolam beams and posts should always be painted with light colours or dark colours with light reflectance value (LRV) of greater than 45%. Colours with an LRV of 45% or less are not recommended, as they can absorb heat which may result in timber distortion and cracking. Because Prolam Glulam is chemically inert it is ideal for corrosive atmospheres such as swimming pools, marine structures, fertilisers and scouring plants where steel is subject to rust and corrosion.

### What finish should I ask for on my beams?

If your beam is going to be used in a situation where appearance is important such as house interiors, halls etc - Visual Appearance Grade A should be specified. If you require a sanded finish, please specify. Non visual grade is intended for use where the product is not seen and occasional chips and voids are acceptable.

Are H5 Laminated Posts certified for in ground use?

Yes. Prolam is leading the way with H5 laminated structural in-ground posts. Codemarked for NZBC Compliance in B1 and B2, it means you can use Prolam in-ground posts with more confidence than ever.

### What is the difference between GL and PL grade?

The GL prefix is a reference to the old term "Glulam", where the PL is the prefix for branded "Prolam" structural timber.

## FAQs - continued

### Will MCA treated Prolam cause corrosion on galvanised fixings?

While this may be a problem with solid unseasoned timber, Prolam does not act in the same way. Because all Prolam is manufactured from material that is kiln dried after treatment, the treatment salts are thoroughly fixed into the timber. They will therefore not subsequently leach out or affect galvanised fixings. For additional protection it is recommended that bolts be greased before inserting into MCA treated Prolam beams that are exposed to the weather.

### How long should I keep the wrapping on?

Wrapping of Prolam beams is primarily to protect them from marking during handling and transport. This is not designed to be a waterproof protection. Once on-site water can often get in under the wrapping and cannot get out. Wrapping should be slit to provide drainage. Wrapping can be left on Prolam beams for as long as possible (even during construction) to protect against accidental marking. Also be aware that partial removal of wrapping to access connections may cause patches of discolouration by exposure to weather.

### Can finished Prolam beams be re-cut and drilled?

Any cutting, drilling or slotting that exposes unsealed timber must be protected with an application of appropriate weather or treatment sealer. Avoid cut-outs, rebating or drilling in the top and bottom edges of Prolam beams. These could cause serious weakness in tension and compression areas. Consult the manufacturer or designer first.

### Do splits along glue lines mean delamination has occurred?

Actual delamination is a failure in the laminating process. While an opening along a glue line may be indicative of delamination there are other more common causes. Typical checking that occurs in large section timber in response to moisture variation will most naturally occur in Prolam along a glue line where the natural continuation of the timber fibres is interrupted. This is often mistaken for delamination. (Ref to Timber Design Journal pg 39&40)

### How serious are checks and why do they appear?

Surface checking and splits occur as timber is allowed to absorb moisture then dries out in response to environmental changes. Surface fibres are more severely exposed to these changes than the inner core and as a result of the movement in these fibres as they dry and shrink, surface splits may occur. Changes in atmospheric conditions will affect the appearance and disappearance of these checks. The effect of surface checks are superficial only and do not usually have any effect on the structural performance of the Prolam.

### How can these checks be minimised?

Prolam® beams are provided with a sealer coating if requested, which controls the ingress of moisture into the timber, and is done before the beams leave the factory. If the beams are exposed to the weather for a greater period than 8-10 weeks, a further coating should be applied. Consult our painting instructions for permanent sealing requirements.

## FAQs - continued

### Where can H1.2 treatment be used?

Prolam treated to H1.2 is only suitable to be used in the building envelope as in NZS3604:2011.

### What is the difference between Visual and Non-Visual grades?

Prolam Visual is made from visually selected sharts that are then finger jointed together into a long length and laminated into the required beam. This grade is recommended for use in highly visual areas and when a paint or stain quality finish is required. Prolam Non-Visual is made up from stress graded timber and is not visually graded. The non-visual grade is recommended where the beams are not seen. [Refer to Prolam finishes]

### Why is bandsawn finished smaller than standard?

Bandsawn finished Prolam posts and beams are 6mm smaller than standard, because we have to cut the bandsawn finish into the beams after they are made. Use the Prolam Online calculator to specify this product.

### What is the fire rating of Prolam?

The BRANZ appraisal states a charring rate from the table below:

Density (kg/m <sup>3</sup> )	Charring Rate (mm/min)
400	0.75
500	0.70
600	0.65

It is recommended that this simplified table of data derived from "White's" model and should be adopted for design of fire resistant timber structures in New Zealand. Prolam density is 550 Kg/m<sup>3</sup>.

### Can you cut drill, machine Prolam after manufacturing?

Yes, because Prolam is pretreated before laminating, all pieces are fully treated, so any cutting etc. does not need apaint on treatment applied to the cut portion. However, any cuts to be sealed as per sealing specifications

### Can I buy direct from Prolam?

All Prolam products are supplied through the main timber merchants nationwide, as well as many timber specialist stores.

### What is the difference between PL8 and PL12?

PL8 is made from SG8 timber, whereas PL12 is made from PL12 timber. PL12 has higher strength and stiffness properties and enables you to achieve bigger spans with larger loaded dimensions. For a similar span and loaded dimension, a PL12 can offer a smaller section where the space is limited or aesthetics are important.

### Does cutting into or notching out a Prolam post or beam affect the treatment?

No this does not. Each laminate used for H3.2 or H5 products is treated right through before it is laminated. This gives a Prolam post or beam around 50% more treatment than a solid timber post or beam which can only be treated from the outside. End grain and/or cut ends and joins should be sealed to prevent any ingress of moisture.

### Can I request samples?

Please email [info@prolamnz.com](mailto:info@prolamnz.com) if you would like to request samples.

## FAQs - Prolam Specifier

### What is the classification of timber to be used for joint design as per table 4.1 of NZS3603?

The classification for Prolam products would be J5.

### What is the tributary joist & bearer span?

The tributary area is a loaded area that contributes to the load on the member supporting that area. On the Prolam Specifier under each non-bracing calculator, the diagram shows how to calculate this.

### Where is the bracing posts chart on the Specifier?

Under <http://specifier.prolamnz.com/resources> refer to the document 'Prolam Bracing Posts'

### Should I go by absolute deflection or residual deflecton?

Depending on the allowance for deflection below the horizontal line, the residual deflection is long term deflection below horizontal after pre-camber and is the recommended value for typical designs. The 'absolute deflection is the maximum beam movement. After selecting 'calculate' these notes are located below the list of products that suit the design.



Scan QR Code for additional FAQ's online  
<https://www.prolamnz.com/technical/faq>

# Building Product Information

## Names and descriptions of products

Names and descriptions can be found on pages 5 – 17 of the Prolam structural timber guide.

## Product Identifier

Product identifiers can be found on pages 5 – 17 of the Prolam structural timber guide

## Legal Trading name

Prowood Ltd is the Legal and trading name of the Prolam products

## Relevant Building Code Clauses

Clause B1 Structure: Performance B1.3.1, B1.3.2 and B1.3.4 for relevant physical conditions of B1.3.3 (a) (b) (g) (h) and (j) [i.e self-weight, imposed gravity loads arising from use, snow, wind and impact]

Clause B2 Durability: Performance B2.3.1 (a) 50 years

Clause F2 Hazardous Building Materials: Performance F2.3.1

## Design requirements

Page 48

## Installation Requirements

Pg 27

## Maintenance Requirements

Pg 29

## Warning or Bans

Prolam products are not subject to any warnings or bans



The ease of using the Prolam program makes specifying a quality product to match clients expectations a no brainer.

Shaun, ITM Blenheim



We see a number of the Prolam products as being the perfect partner in achieving great architecture with a sustainable solution.

Mark, Bishop Architecture

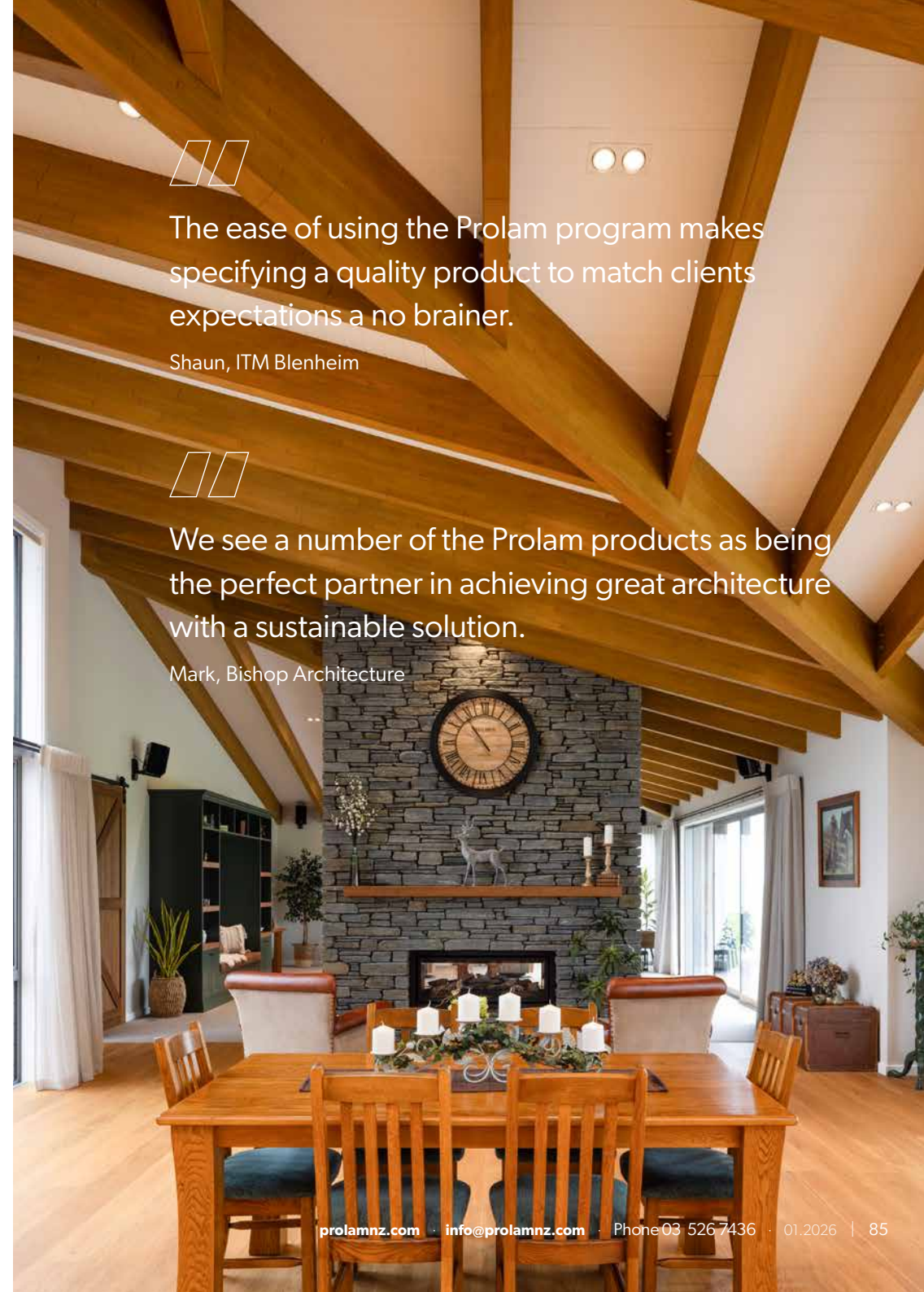

# Licensed Builders Practitioners Details

## LBP Points Here

This Prolam® Builders Booklet will give you LBP points if you record reading it as your **Skills Maintenance Activity**.

- ▶ Log onto <https://lbp.dbh.govt.nz/OnlineAccount/Login.aspx> to set up your user account, or if you are already set up, log in here to record your learning.
- ▶ Or you can record your learning by making a note in your Diary.
- ▶ One hour of learning = 1 point
- ▶ Be sure to write down how and what you learnt and include the date and the time taken.
- ▶ You can also go to our web site and download a Q & A sheet as a record of learning.



# Record of Skills Maintenance Form

**Return this form with your annual licence fee**

Full Name \_\_\_\_\_

LBP Number \_\_\_\_\_

Enter details of your Skills Maintenance. Remember to include all of your activities, and include additional pages if needed

Activity \_\_\_\_\_

Date Completed \_\_\_\_\_ Hours \_\_\_\_\_

Details of Activity \_\_\_\_\_

Activity \_\_\_\_\_

Date Completed \_\_\_\_\_ Hours \_\_\_\_\_

Details of Activity \_\_\_\_\_

Activity \_\_\_\_\_

Date Completed \_\_\_\_\_ Hours \_\_\_\_\_

Details of Activity \_\_\_\_\_

### Declaration

I declare this is a true record of my skills maintenance activities. I understand that the Registrar can ask to see my personal skill maintenance records that support this claim. I understand that it is an offence under the Building Act 2004 to provide incorrect or misleading information.

Signature \_\_\_\_\_ Date \_\_\_\_\_

### Please Post to: The Registrar

Ministry of Business, Innovation and Employment,  
PO Box 50041, Porirua 5240



## Planning a project?

Our team of experts are ready to assist.

Register to our Online Specifier [specifier.prolamnz.com](https://specifier.prolamnz.com)



**Prolam**<sup>®</sup>

Engineered Laminated Timber

03 526 7436

info@prolamnz.com

prolamnz.com